



Defining Quality. Building Comfort.



Value in the Air

Why Direct Drive Backward Curved Plenum Fans?



Table of Content

Introduction to Fans	4
Fan Curves	4
Fan Laws	5
Fans and Air Movement	8
Axial Flow and Centrifugal Fans	8
Forward and Backward Curved Fans	8
Forward Curved Fans	9
Backward Curved Fans	10
Housed and Plenum Fans	11
Belt Driven and Direct Drive Fans	13
Fan Class	14
Fan Selection	15
Point of Operation and Fan Blade Operating Characteristics	15
Fan Speed and Performance	15
Banding and Narrow Width Wheels	16
Selecting Supply Fans for Variable Speed Operation	16
Fan System Effects	18
Fan Pressure and Velocity Relationship	18
Fan Inlet System Effects	19
Spacing Of Fans at the Inlet	19
Belt Guards	21
Belts and Sheaves	21
Fan Inlet Velocity Flow Probes	22
Combined Inlet Losses	23
Elbows and Tees at Discharge	23
Discharge Dampers	23
Unducted Discharge Losses	24
Plenum Fan Discharge System Effects	24
Fan Efficiency	25
Fan Mechanical Efficiency	25
Fan Static Efficiency	25
Fan Application Efficiency	26
HVAC System Energy Efficiency	29
Variable Air Volume and Constant Volume Fan Control Schemes	30
Variable Air Volume Systems	30
Constant Volume Systems	30
System Efficiency Example	30
AAON Direct Drive Backward Curved Plenum Fans	33
Blow-Through Designs	33
Application Flexibility	33
Multiple Fan Redundancy	34
Advanced Selection Tools	34
References	Back Cover

Introduction to Fans

AAON equipment has been designed and engineered for both performance and energy efficiency. From standard equipment designs to complex heating and cooling systems, AAON provides performance and energy efficiency solutions for virtually all applications. Fans are one of the most important components of any HVAC (Heating, Ventilating and Air Conditioning) system in terms of performance and energy efficiency.

Direct drive, backward curved plenum fans are the optimum choice for practically all commercial HVAC applications. The following information will show the many reasons why.

First, the basics of fans, fan curves and fan laws will be introduced. Next, fan selection will be covered, including points of operation, fan widths and variable speed operation fans. Fan system effects will then be covered including inlet, discharge, belt and plenum fan discharge system effects. Then fan efficiency and unit efficiency will be summarized. Finally, an overview of AAON direct drive plenum fans will conclude the information. References for the information provided are available on the final page.

Fan Curves

Fan performance data can be represented by fan curves. These curves are generalized plots of fan test data taken in a laboratory environment. In the United States, the standard test method used for generating fan aerodynamic performance data is the Air Movement and Control Association (AMCA) Standard 210.

Although a fan manufacturer may produce many different sizes of a basic fan design, and operate these fans over a wide range of speeds, only a few sizes are usually tested at varied running speeds to characterize the whole family of fans. Other sizes of fans and fans running at speeds different than those tested are extrapolated using the Fan Laws.

A basic fan curve is shown in Fig. 1. The fan speed curve (rpm) is plotted as static pressure (in. wg) vs. flow (cfm) and represents the range of operating points that a fan will achieve at a discrete speed.

The power curve (bhp) shows the fan shaft power required at each flow (cfm) condition at this discrete fan speed. Likewise, the static efficiency curve (%) shows the static efficiency at each flow (cfm) condition at the fan speed.

For a given application, the flow and static pressure required define a point of operation. This point of operation, at a given static, will determine the speed of the

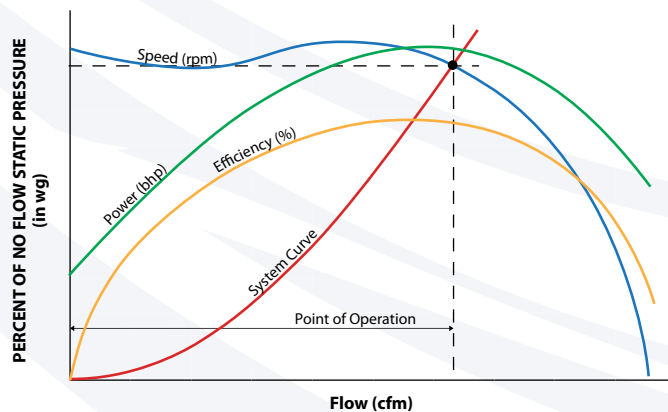

Fig. 1: Typical Backward Curved Fan Curve

fan required. Reading vertically up or down from this point of operation along a line representing the flow, determines the power required and the static efficiency achieved.

For a given fixed physical system, the static pressure required to push a given flow through that system follows the system curve. For a given system, the system curve does not change unless the system is physically changed. A system could be changed if ductwork is added or removed, dampers are adjusted to a different condition, or when filters become loaded with dirt.

The system curve can be mathematically represented by the following formula:

$$P = R \cdot Q^2 + P_{Min}$$

Where:

- P = Static Pressure (in.wg)
- R = Flow Resistance for the Distribution System
- Q = Flow (cfm)
- P_{Min} = Dynamically Maintained Controlled Static Pressure at some part in a VAV System

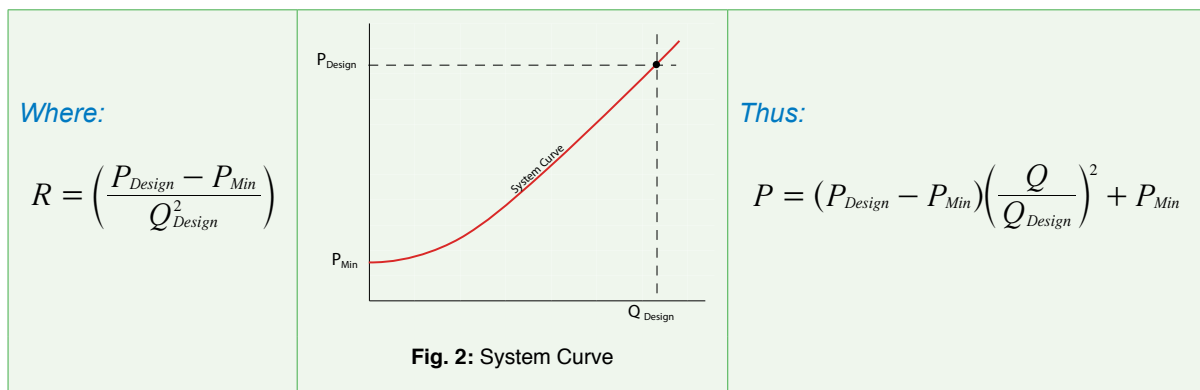

Most fan manufacturer's software assumes that $P_{Min} = 0$. P_{Min} is useful when determining the system behavior of a Variable Air Volume (VAV) system.

Fan Laws

When interpolating performance between different operating conditions, a set of equations referred to as the Fan Laws can be used. The three basic fan laws are:

$$Q_2 = Q_1 \cdot \left(\frac{D_2}{D_1} \right)^3 \cdot \frac{N_2}{N_1}$$

$$HP_2 = HP_1 \cdot \left(\frac{D_2}{D_1} \right)^5 \cdot \left(\frac{N_2}{N_1} \right)^3 \cdot \frac{\rho_2}{\rho_1}$$

$$P_2 = P_1 \cdot \left(\frac{D_2}{D_1} \right)^2 \cdot \left(\frac{N_2}{N_1} \right)^2 \cdot \frac{\rho_2}{\rho_1}$$

Where:

- Q = AirFlow (cfm)
- HP = Fan Power Input (Horsepower)
- D = Fan Size or Impeller Diameter (in.)
- P = Fan Pressure (in.wg)
- N = Fan Rotational Speed (rpm)
- ρ = Air Density (lb/ft³)

Fans are volumetric machines. Fans move a constant volume of air at a constant rotational speed. The static pressure capabilities will decrease with a decrease in absolute operating pressure. A change in altitude is the most common cause for a significant change in absolute operating pressure.

When correcting for altitude, the air density ratio can be expressed as a percent density using Fig. 3.

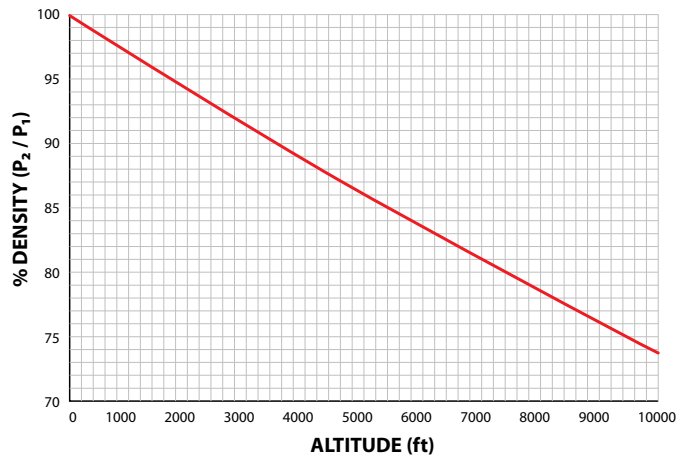

Fig. 3: Effects of Altitude on Air Density Ratio

There are several important facts about the Fan Laws to remember:

- a) *When extrapolating between fan sizes, the fans must be geometrically similar. The fans must have the same number of blades. The fans also need to be of a constant dimensional scale. Blade dimension and fan width needs to be proportional. Disproportionate shafts, bearings or other features will affect the accuracy of the Fan Laws if the fans are not exactly proportional.*
- b) *Because geometric similarity is very difficult to obtain in practice, fans should in general only be scaled from smaller to larger and never from larger to smaller. Although diameter relationships are useful within fan programs to extrapolate new curves from smaller diameter fans, diameter relationships have limited usefulness in hand calculations.*
- c) *Fan Laws operate along a system curve assuming that at zero flow there will be zero static imposed on the system. For example, given a fan point of operation at a given flow (cfm), static pressure (in. wg), fan speed (rpm) and power input (hp), one can find the new fan speed (rpm), required to achieve a higher flow (cfm) along the system curve. This will provide a new higher static pressure (in. wg) the system will encounter and the new power input (hp) at that condition. Neither power input (hp) nor fan speed (rpm) needed to obtain a higher flow (cfm) of the same static pressure (in. wg) can be found by using the Fan Laws.*

Example 1

GIVEN:

A 30" fan operating in a system at 1,040 rpm, 10,000 cfm at 2.18 in. wg of static pressure and 5.77 bhp at sea level.

FIND:

The new operating parameters needed to operate at 12,000 cfm in the same system.

SOLUTION:

$$N_2 = N_1 \cdot \frac{Q_2}{Q_1} = 1040 \text{ rpm} \cdot \frac{12,000 \text{ cfm}}{10,000 \text{ cfm}} = 1248 \text{ rpm}$$

$$HP_2 = HP_1 \cdot \left(\frac{N_2}{N_1}\right)^3 = 5.77 \text{ bhp} \cdot \left(\frac{1248 \text{ rpm}}{1040 \text{ rpm}}\right)^3 = 9.97 \text{ bhp}$$

$$P_2 = P_1 \cdot \left(\frac{N_2}{N_1}\right)^2 = 2.18 \text{ in. wg} \cdot \left(\frac{1248}{1040}\right)^2 = 3.14 \text{ in. wg} \quad (\text{Static Pressure})$$

Example 2

GIVEN:

The same conditions above, find the bhp required and static pressure imposed if the same system was located in Denver, CO at 5,000 ft. elevation.

FIND:

The required brake horsepower and fan pressure.

SOLUTION:

From the Fan Laws one can see that fans are assumed to be constant volume machines. Regardless of air density the same volume is moved at the same rotational speed. From Fig. 3, it is shown that at 5,000 ft. elevation the air density is 86% of air density at sea level.

$$N_1 = 1040 \text{ rpm}$$

$$HP_2 = HP_1 \cdot \left(\frac{\rho_2}{\rho_1}\right) = 5.77 \text{ bhp} \cdot 86\% = 4.96 \text{ bhp}$$

$$P_2 = P_1 \cdot \left(\frac{\rho_2}{\rho_1}\right) = 2.18 \text{ in. wg} \cdot 86\% = 1.87 \text{ in. wg}$$

From this example, one can see that altitude does not affect volumetric flow. However, the mass flow is less because the density of air is less. Since the mass flow is reduced, the system losses are also reduced. Less work is done by the fan with less power.

Fans and Air Movement

In a HVAC system, air movement is most commonly accomplished with either axial flow fans or centrifugal fans. Centrifugal fans can include either forward curved or backward curved impellers. Backward curved fans can also be applied as housed or unhooded. Fans can be belt driven or direct drive. Each of these types of fans will be compared along with an explanation of the class rating of fans.

Axial Flow and Centrifugal Fans

An axial flow fan propels air in an axial direction, parallel to the fan's shaft, with a swirling tangential motion created by the rotating impeller blades. The air velocity is increased through rotational force, which produces velocity pressure (kinetic energy) and a small amount of static pressure (potential energy). Axial flow fans are well suited for applications that require moving large quantities of air with low static pressure requirements, such as for condensers, exhaust applications, spot cooling and boosting airflow through long ductwork. The rotor wheel of an axial flow fan is shown in Fig. 4, the direction of airflow is shown in Fig. 5.

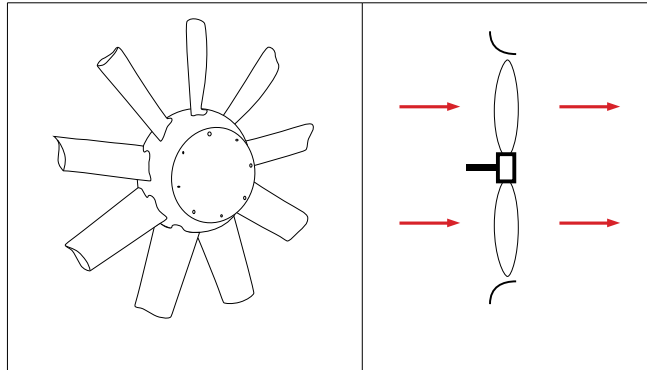

Fig. 4: Axial Flow Fan Rotor Wheel

Fig. 5: Axial Flow Fan Direction of Airflow

A centrifugal fan propels air in a radial direction, perpendicular to the fan's shaft. Airflow is induced by the centrifugal force generated in a rotating column of air, producing static pressure (potential energy), and by the rotational velocity imparted to the air as it leaves the tip of the blades, producing velocity pressure (kinetic energy). This makes centrifugal fans well suited for air movement applications requiring medium to high static pressure capabilities and low noise requirements such as supply and return fans. The impeller wheel of a centrifugal fan is shown in Fig. 6, the direction of airflow is shown in Fig. 7.

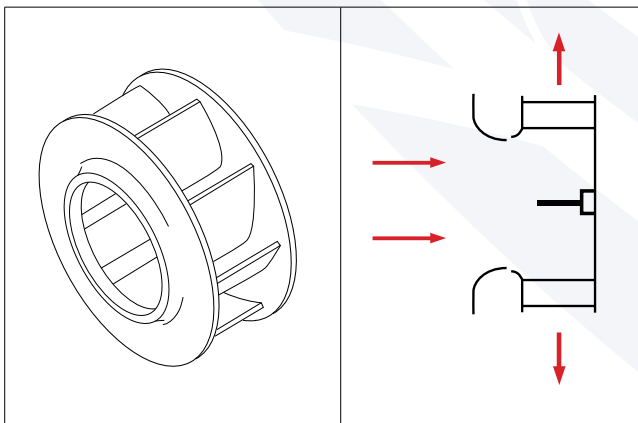

Fig. 6: Centrifugal Fan Impeller Wheel

Fig. 7: Centrifugal Fan Direction of Airflow

Forward and Backward Curved Fans

Centrifugal fans are the most common type of supply fans used in the HVAC industry. The most common types of centrifugal fan impellers are the forward curved impeller and the backward curved impeller. Backward curved, backward inclined and airfoil impellers have similar performance curves and thus the following backward curved fan information applies to backward inclined and airfoil fans, as well.

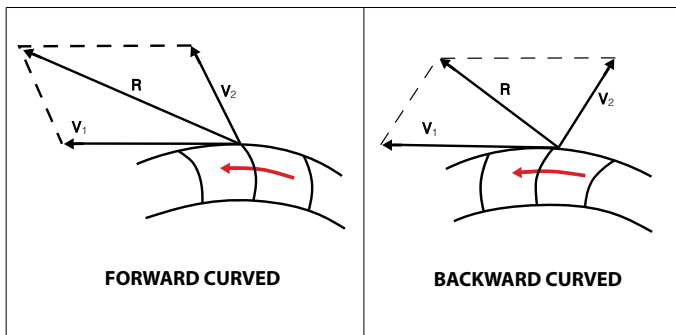

Fig. 8: Impeller Vector Diagrams

Fig. 8 shows the vector diagrams of the forces from forward curved and backward curved impeller blades. Vector V_1 represents the rotational velocity, and vector V_2 represents the radial velocity of the airflow between the blades. Vector R represents the resultant velocity for each of these impeller blade types. Note that the magnitude of the vector

R for the forward curved impeller is greater than for the backward curved impeller. Because the pressure produced by a fan is a function of the forward motion of the air at the tip of the blade, a forward curved fan with a larger number of blades will operate at a lower speed for a given duty than a backward curved fan. A forward curved impeller wheel is shown in Fig. 9 and a backward curved impeller wheel is shown in Fig. 10.

Forward Curved Fans

Forward curved fans operate at lower speeds and pressures compared to backward curved fans, which permits lighter construction of the impeller, shaft, bearings and housing. The light construction results in a low cost fan with a relatively high airflow at low static pressures.

The performance curve of a forward curved fan is shown in Fig. 11. Special considerations must be made when selecting a forward curved fan because the static pressure curve has a pronounced dip, where the fan will stall, near the 40% free delivery point. Any selection to the left of the peak point should be avoided because the same static pressure may result in the fan operating at a lower flow rate, and then at a higher flow rate, causing fan pulsations and a large increase in noise generation.

Single fans can operate in the stall region without causing structural damage to a forward curve fan since the high blade count results in only small forces imposed at any individual blade in stall. Though good peak efficiencies are obtained on either side of the peak, selections should be limited to 45% or greater of free delivery to prevent fan operation in the undesirable stall region.

The fan curves of a single forward curved fan and of two identical forward curved fans operating in parallel, usually referred to as forward curved double width double inlet (FC DWDI), are shown in Fig. 12. Curve

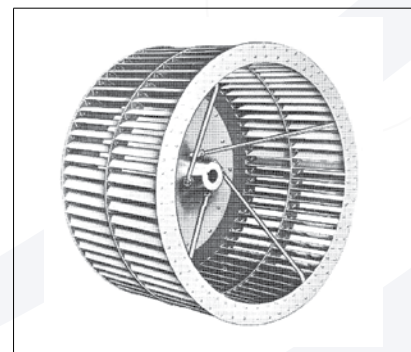

Fig. 9 : Forward Curved Impeller Wheel



Fig. 10: Backward Curved Impeller Wheel

The performance curve of a fan is a plot of the pressure rise and power required versus volumetric flow rate at a constant speed. The shape of the curve depends on the blade type.

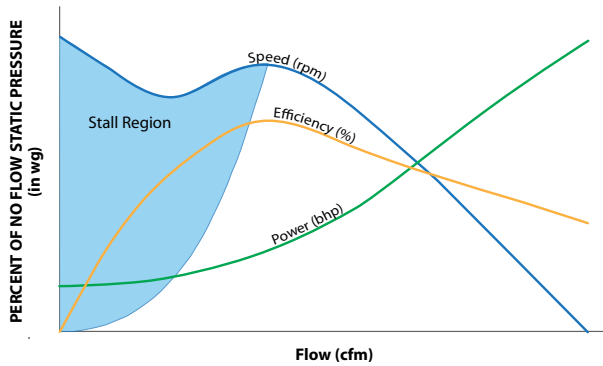

Fig. 11: Characteristic Performance Curve of a Forward Curved Centrifugal Fan

A-A shows the pressure characteristics of a single fan. Curve C-C is the combined performance of the two fans. The unique figure-8 shape is a plot of all possible combinations of volume flow at each pressure value for the individual fans. All points to the right of point CD are the result of each fan operating at the right of its

peak point of rating. At points of operation to the left of point CD, it is possible to satisfy system requirements with one fan operating at one point of rating while the other fan is at a different point of rating. For example, consider system curve E-E, defined by 1.00 in. wg and a volume of 5000 cfm. The requirements of this system can be satisfied with each fan delivering 2500 cfm at 1.00 in. wg, point CE. The system can also be satisfied at point CE' with one fan operating at 1400 cfm at 0.9 in. wg, while the second fan delivers 3400 cfm at the same 0.9 in. wg.

Note that system curve E-E passes through the combined performance curve at two points. Under such conditions, unstable operation will result. Under conditions of CE', one fan is under loaded and operating at poor efficiency. The other fan delivers most of the requirements of the system and uses substantially more power than the under loaded fan. This imbalance may reverse and shift the load from one fan to the other causing pulsation in the duct, noise and structural damage to the assembly. In order to prevent this instability, forward curved fans in parallel operation should always be selected further to the right of the peak. Selection to the right of the peak will decrease the total efficiency but will prevent multiple combinations of volume flow at a given pressure value.

Backward Curved Fans

An attractive feature of the backward curved impeller is the non-overloading characteristic of its horsepower curve. As Fig. 13 illustrates, the horsepower increases to a maximum as airflow increases, and then drops off again toward free delivery. This means that a motor selected to accommodate the peak horsepower will not overload, overheat or burnout, despite variations in the sys-

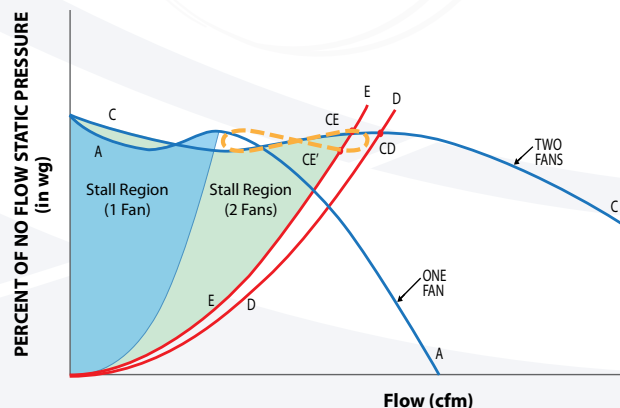

Fig. 12: Two Forward Curved Centrifugal Fans in Parallel Operation

tem resistance or airflow, as long as the fan speed remains constant. This is in contrast to the overloading tendency of the forward curved fan seen in Fig. 11.

Because backward curved fans operate at higher speeds for a given pressure than forward curved fans, backward curved fans must be more sturdily

constructed than their forward curved counterparts. High speed operation and sturdy construction also make the backward curved fan suitable for applications with higher static pressure requirements, where a forward curved fan cannot be used. This construction and capability will result in a greater first cost versus the forward curved fan, however, this cost is most often offset by the higher backward curved fan's operating efficiency.

The backward curved impeller can require up to 15% less power than forward curved fans at the same duty requirements. Typical forward curved fan peak efficiencies are in the range of 65 to 70%, while the backward curved impeller offers peak efficiencies between 75 and 80%. This makes the backward curved impeller a good choice for any application that benefits from higher efficiencies, such as large systems or those that require the fan to be run for many hours. In these types of applications, any discrepancy in first cost is quickly

paid back by the lower operating cost as a result of the higher operating efficiency.

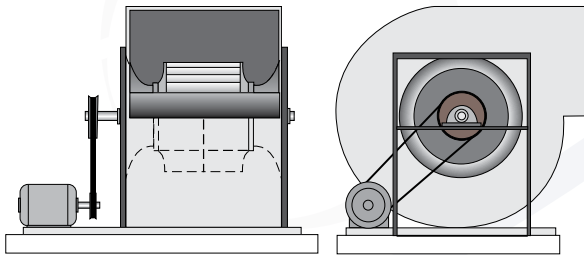

Fig. 14: Housed Fan

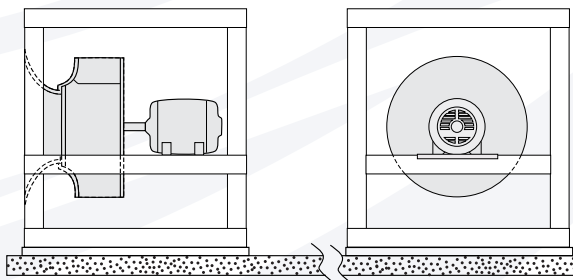

Fig. 15: Plenum (Unhoused) Fan

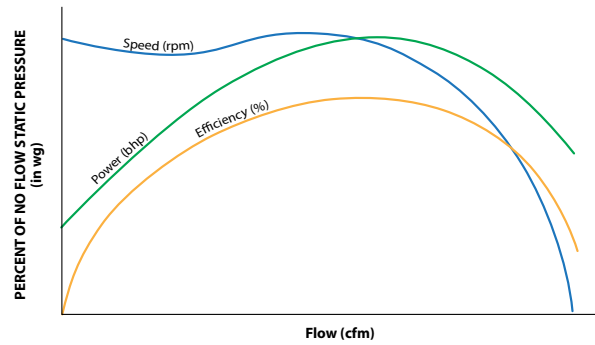

Fig. 13: Characteristic Performance Curve of a Backward Curved Centrifugal Fan

Backward curved impellers are known as nonoverloading because they do not exhibit the same characteristic tendency to overload that the forward curved fan does.

Housed and Plenum Fans

The forward curved fan is highly dependent on the housing for performance; therefore, forward curved fans are not suitable for unhoused fan applications. Unhoused centrifugal fans are also referred to as plug or plenum fans. Without a housing a forward curved fan becomes unstable and exhibits relatively poor performance. The air leaving a backward curved fan has less of its total energy in the form of velocity pressure than does the air leaving a forward curved fan. Because more of its energy is in the form of static pressure, a backward

curved fan loses less energy in the process of converting from velocity pressure to static pressure in the housing. Therefore, a backward curved fan can operate quite satisfactorily without a housing, making it suitable for plenum fans.

A housed fan is shown in Fig. 14 and a plenum fan is shown in Fig. 15. **Unlike the housed fan, a plenum fan does not need an extended length of ductwork for the velocity pressure to be converted to static pressure.** With a plenum fan more of the air's energy leaves the fan in the form of static pressure and, without a housing, air is not pushed against the housing creating an unbalanced outlet velocity profile. **Instead, air leaves the plenum fan with a more uniform velocity profile allowing ductwork turns to be connected directly to the air handler's discharge plenum without the system effect losses experienced by a housed fan.**

For housed fans, utilizing forward or backward curved impellers, the design of the duct at the fan outlet has a great effect on the system performance. For the most efficient fan performance, the duct at the fan outlet should be straight and the same size as the fan outlet. It should be long enough so that the air velocity becomes uniform across the face of the duct. Achieving a uniform air velocity in the duct involves a process called static regain.

Static regain is the process of converting velocity pressure to static pressure. The total pressure in a duct system is the sum of velocity pressure and static pressure. Static pressure is the pressure that causes the air in the duct to flow, and velocity pressure is the pressure that results from the air movement.

$$P_T = P_v + P_s$$

Where:

P_T = Total Pressure

P_v = Velocity Pressure

P_s = Static Pressure

Fig. 16 shows the air velocity profiles in a duct at various distances from the outlet of a housed centrifugal fan. The air in the fan is pushed against the outside of the housing by the movement of the fan wheel. Therefore, at the fan outlet, there is a high velocity at the top of the fan outlet. However, at the bottom of the fan outlet, there is a negative velocity, because the air is swirling back to the fan at the cut-off plate, attempting to re-enter the fan. At point A in Fig. 16, the velocity pressure is high and the available static pressure is low. As the air moves down the duct, the velocity of the air becomes more uniform across the duct, and the static pressure increases as the velocity pressure decreases. At point B in Fig. 16, the air velocity is uniform across the duct and low compared to the outlet velocity (point A).

Remember that total pressure is the sum of velocity pressure and static pressure. The total pressure in the duct at point B is about the same as it was at point A, therefore as the velocity pressure has decreased, the static pressure has increased. In other words, the system

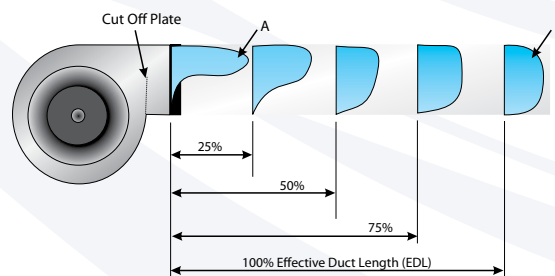

Fig. 16: Duct velocity profiles showing static regain

has gained static pressure. This is static regain. The system now has more potential to overcome the resistance in the system and thus the system can deliver more air.

At point B in Fig. 16, the air velocity is uniform across the duct area and has slowed. This is the point of highest static regain. Duct takeoffs and turns or elbows should be avoided prior to point B because airflow in ducts attached prior to point B will have significant system effect losses that must be accounted for in the sizing of the duct and fan. The distance from A to B is called the 100 percent effective duct length. The housed fan outlet should be designed with straight duct for the 100 percent effective duct length, and fittings should not be put near the fan outlet, in order to eliminate system effect at the outlet.

Calculating the 100 percent effective duct length depends upon the air velocity at the fan outlet:

- If the outlet velocity is less than 2,500 fpm: 100 percent-effective duct length = 2.5 x Duct diameter
- If the outlet velocity is more than 2,500 fpm: 100 percent-effective duct length = fpm/1000 x Duct diameter
- To calculate the duct diameter: $D = \frac{2wh}{w + h}$
Where h and w are the duct height and width

Belt Driven and Direct Drive Fans

Because direct drive fan applications couple the motor shaft directly to the fan wheel, it is important to understand how this coupling affects the motor size when performing fan selections. The absence of pulleys and belts are a service and maintenance benefit in direct drive applications, however, the removal of the pulleys and belts eliminates one fan speed adjustment method. This sometimes requires direct drive motors to have larger rated horsepower than a belt driven system.

Electric motors are rated in horsepower. The rating condition for an electric motor is for a given full load synchronous operating speed, line voltage, phase and operating hertz. When a motor operates at a different speed, voltage, phase or frequency the horsepower available will be different. A variable frequency drive (VFD) varies the voltage and frequency of the rated conditions input to the motor and thereby modifies the operating speed of the motor. Motors are not capable of constant horsepower at variable speed. Motors can deliver a nearly constant torque at varying speed. The relationship of torque (τ), horsepower and speed is:

$$hp = \frac{\tau \cdot rpm}{5252}$$

The number 5252 is the result of combining different conversion factors together into one number.

$$1 \text{ hp} = 33,000 \left(\frac{\text{ft} \cdot \text{lb}}{\text{min}} \right)$$

There are 2π radians in every revolution.

$$5252 = \frac{33,000 \left(\frac{ft \cdot lb}{min} \right)}{2\pi}$$

At a constant torque, the horsepower required to operate a motor at a reduced speed and with given brake horsepower is:

$$hp_{Available} = hp_{Rated} \left(\frac{rpm}{rpm_{Rated}} \right)$$

This reduction in available horsepower at lower speeds is very important when selecting direct drive fans where it is unlikely that the design point of selection will be at the motor's rated rpm. Although the direct drive fan is much more efficient by avoiding belt drive losses, a larger motor may be needed to provide the proper horsepower the fan requires at its operating speed. **The motor will be larger but the power consumed will be less.**

Example 3

GIVEN:

A motor designed to operate at 1760 rpm is attached to a fan and the system is operating at conditions which require 2.7 bhp.

FIND:

The rated horsepower requirement of the motor if a larger fan operating at 1300 rpm is applied and the same air flow and static pressure are to be maintained.

SOLUTION:

The required horsepower increase is shown in the following equation:

$$hp_{Required} = 2.7 \left(\frac{1760}{1300} \right) = 3.7 hp$$

Where a 3 hp fan would have been adequate to operate the fan if it were running at the motor's rated speed, a 5 hp motor will be required to operate at the reduced speed.

Fan Class

Fan manufacturers rate fans for the maximum rpm for which the fan can be applied and run on a continuous basis. This maximum RPM is dependent on the structural integrity of the wheel assembly and the wheel diameter. Based on the fan curve defined by this maximum rpm rating as a function of outlet velocity, AMCA classifies housed fans in one of three pressure classes, as shown in Fig. 17. To be a Class II fan, the entire fan operating range must be capable of operating at all points above the line defined by 3,000 FPM at 8.5 in. wg static pressure and 4,175 FPM at 4.25 in. wg static pressure. It is important that fans be selected so the application will never exceed the maximum rated rpm.

Fan Selection

In order to properly select fans, it is important to understand how a fan works. As in most areas of engineering, fan selection consists of making the best balanced compromise between the many factors and characteristics available.

Point of Operation and Fan Blade Operating Characteristics

Fans are aerodynamic devices. In order to achieve the highest efficiency possible within a design, fan blades are designed to take advantage of aerodynamic lift. Looking at a typical fan curve in Fig. 18, notice the peak efficiency and peak power are close to the peak static of the rpm curve. This is the optimal operating efficiency of the fan wheel because the air flowing through the blades is smoothly attached to the blade and obtaining the maximum lift from each blade. Although this is the most efficient selection, a small change in pressure results in a large change in flow. There is little or no safety factor available with a peak efficiency selection.

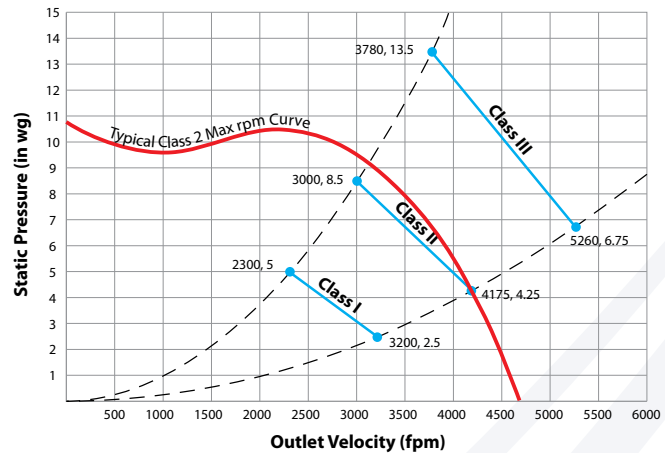

Fig. 17: AMCA Fan Class

As the operating point moves to the right on the fan curve (lower static, higher flow) as in Fig. 19, the blades are no longer at the optimum angle of attack to the entering air and begin to push the air with less aerodynamic lift involved. Air is still moved by the fan but in a much less efficient manner.

A fan operating left of the peak static capacity, as shown in Fig. 20, is operating in an unstable region. This is referred to as the surge or stall condition. This is because the fan blade is running at too low a velocity in the air stream and causing some blades to stall or vortex. This is an unstable operation and different blades will stall out at different times causing the air flow to alternately surge and stop through the blade passage. In addition to being inefficient, fans running in the unstable region can cause severe vibration, pressure pulsations and even structural damage to fan wheel itself or its mounting.

Fan Speed and Performance

A characteristic of fans is that the tip speed (angular velocity of the outside edge of the wheel) is related to its static pressure capability. For a given diameter fan, the fan speed sets the peak static. To move the point of operation to the left for a given condition capability, select a larger diameter fan running at a slower speed. To move the point of operation to the right, select a smaller diameter fan running at a faster speed as shown in Fig. 21. Note that as fans are selected closer to the static peak the unstable region is approached.

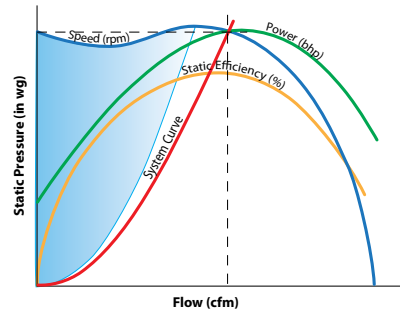
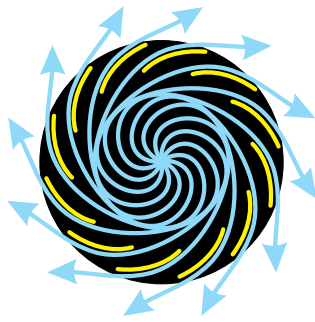

Fig. 18: Peak Efficiency

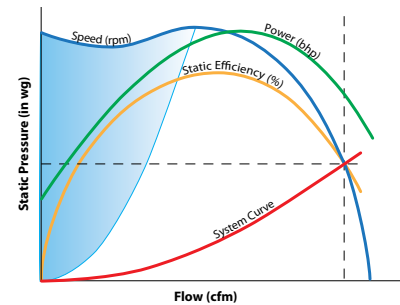
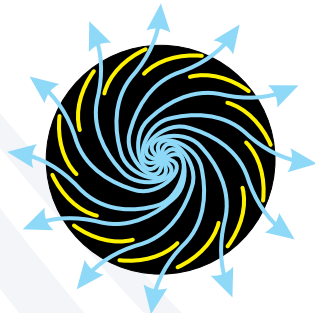

Fig. 19: Low Efficiency

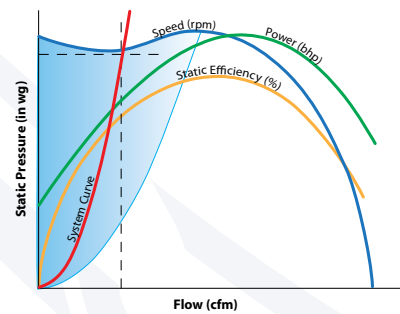
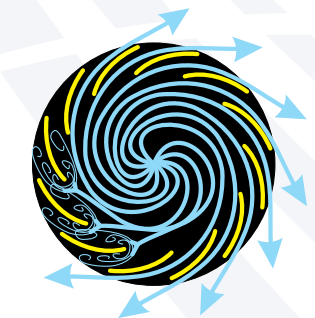

Fig. 20: Stall Condition

Banding and Narrow Width Wheels

Using a narrow wheel width or banding a wheel to make it effectively narrower, can also be used to change the point of operation. If the wheel width is narrowed, the fan rpm curve can be steeper. It can then be sped up to match the operating point, increasing the fan static capability as shown in Fig. 22.

Even though this allows the use of a larger wheel at a farther right of peak operating condition, narrowing and banding can negatively affect the efficiency of the fan.

Selecting Supply Fans for Variable Speed Operation

There are two common reasons to vary the speed of a supply air fan. The first is to offset filter loading in systems where constant supply air flow is critical to the space. The second is to maximize energy savings

in a VAV system. These two variable speed systems behave quite differently and require different strategies for fan selection. For the filter loading case, the system curve changes due to an increase in pressure loss through the filters.

Moving upward on the performance curve represents the filters loading at constant cfm. Moving vertically on the performance curve moves the operating point proportionately farther left on the speed curve as shown in Fig. 23. When selecting fans for this case it is important to analyze both the maximum allowable filter loading, as well as, the clean filter loading points of operation to ensure the fan does not operate in an unstable region.

In a VAV system with space temperature control, the volume of air supplied to the space is varied in reaction to the building loads. Since many areas of the building may have different loads at different times, the system must be able to react to a wide range of conditions. Air to each of the building zones is controlled through a terminal unit that has a modulating damper that regulates the volume of air to each space. In order to ensure design air volume is available to the last VAV terminal unit on the longest run from the air handler, a static pressure sensor is generally located in the duct 2/3 of the distance down the longest run. This static pressure sensor controls the speed of the fan in the HVAC unit to maintain a fixed static pressure (control static pressure) at this point in the duct. Even if all the VAV terminal units were to close completely, (zero air flow) the logic of the control system would try to regulate the fan speed to maintain this **control static set point**.

In Fig. 24, the system curve is offset up to the control static pressure at zero flow. At some point in the turn down, the fan will slow to a point where it is no longer capable of maintaining the control static and will be forced to run in the unstable region. The farther to the right on the curve the full load selection is made, the higher the turn down that can be achieved, as shown in Fig. 25. Setting the control static set point as low as possible, in relation to the design peak static, will maximize the turn down capabilities.

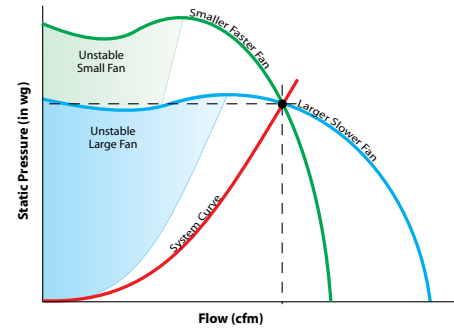

Fig. 21: Larger & Smaller Fans

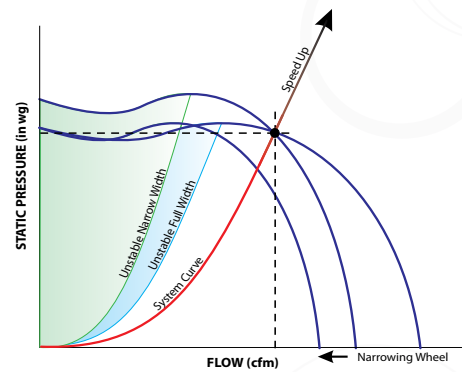

Fig. 22: Narrow Wheel Effect

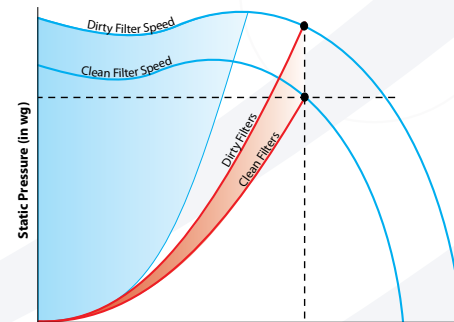

Fig. 23: VAV System with Filter Loading

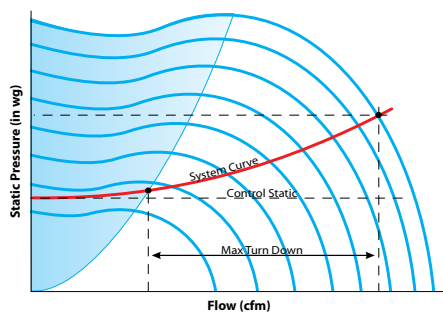

Fig. 25: VAV System Selected Further Right of Peak Static

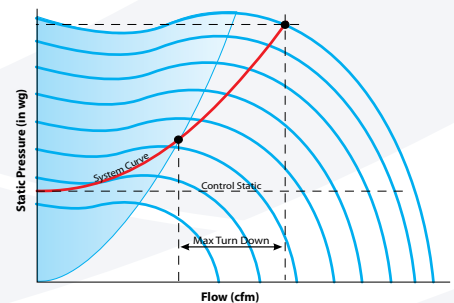

Fig. 24: VAV System Selected Close to Peak Static & Efficiency

In VAV applications, it is critical to know the system control static and have some expectation of the turn down that will be required on the project. In order to perform a proper fan selection, the full range of expected operation must be identified and stable fan operation confirmed at both extremes.

This fan pressure capability issue does not apply to return or exhaust fans on VAV systems as there are no dynamic control dampers in the duct regulating the pressure of the fan. In the case of the return or exhaust side of the system, the system curve will start at zero pressure required at zero flow. Therefore, the fan operating point on the rpm curve will remain at the same proportional point throughout the full range from no flow to design flow.

Fan System Effects

Fan ratings are based on laboratory tests performed in ideal standardized conditions. In application, these ideal conditions are rarely, if ever, duplicated. When fans are applied in real world conditions, performance must be adjusted for losses that occur due to the less than ideal conditions.

Fan Pressure and Velocity Relationship

The relationship between pressure and velocity of the air stream can be shown using Bernoulli's equation where:

$$\frac{P_1 - P_2}{\rho_{air}} = \frac{(V_2)^2 - (V_1)^2}{2g}$$

Assume the initial velocity of the air is equal to 0, therefore:

$$\frac{P_1 - P_2}{\rho_{air}} = \frac{(V_2)^2}{2g}$$

Solving for the change in pressure yields:

$$\Delta P = \rho_{air} \cdot \left(\frac{(V_2)^2}{2g} \right)$$

$$\rho_{air} = 0.075 \text{ lb/ft}^3 \quad (\text{Density of Air at Sea Level})$$

$$g = 32.17 \text{ ft/sec}^2 \quad (\text{Gravitational Constant})$$

$$\Delta P = 0.075 \text{ lb/ft}^3 \left(\frac{V^2}{2 \cdot 32.17 \text{ ft/sec}^2} \right)$$

HVAC calculations often express pressure in terms of inches of water gauge (wg). The previous equation must be further developed so that the solution is given in inches of water gauge. Water at 40°F has a density of 62.4 lb/ft³ and therefore exhibits 62.4 pounds of force, per square foot, for every foot of height in the water column.

Therefore, $62.4 \text{ lb/ft}^3 = 62.4 \text{ lb/ft}^2$ per foot height of water. To convert this number to inches of water, divide by 12.

$$62.4 \text{ lb/ft}^2 \text{ per ft wg} \left(\frac{1 \text{ ft wg}}{12 \text{ in. wg}} \right) = 5.2 \text{ lb/ft}^2 \text{ per in. wg}$$

Adding this factor to the equation and converting seconds² to minutes² yields:

$$\Delta P = \frac{\frac{0.075 \text{ lb/ft}^3}{\left(\frac{5.2 \text{ lb/ft}^2}{\text{in. wg}} \right)} \cdot V^2}{2(32.17 \text{ ft/sec}^2) \left(\frac{3600 \text{ sec}^2}{\text{min}^2} \right)} = \left(\frac{V}{4005} \right)^2$$

System effects can be segregated into inlet effects and outlet effects. Most system effects are velocity dependent; the higher the velocity the greater the reduction in performance. System effects can be expressed as an additional pressure loss encountered as the fan is applied. These cannot be directly measured as the losses tend to be internal to the fan. The losses can only be determined as the difference in performance with and without the effect applied. These losses are expressed as:

$$\Delta P = P_v \cdot C$$

Where:

ΔP = The Additional System Pressure Loss Applied to the Fan

P_v = Velocity Pressure at the Fan Inlet or Outlet

C = Loss Coefficient of the System Effect

In the following text, the value for the loss coefficient C is discussed for various arrangements. Velocity pressure is the dynamic velocity pressure component of moving air. It is calculated by:

$$P_v = \left(\frac{V}{4005} \right)^2$$

At sea level, standard air, 0.075 lb/ft^3

$$P_v = \left(\frac{V}{1097} \right)^2 \cdot \rho$$

At any other condition where ρ = density

Fan Inlet System Effects

Inlet system effects can be caused by inlet obstructions or by asymmetrical air flow into the fan inlet. Although inlet system effects are best determined by test, in many cases this data is not readily available.

Spacing Of Fans at the Inlet

Open inlet tests of fans for ratings are performed in an open room with no restrictions close to the fan inlet.

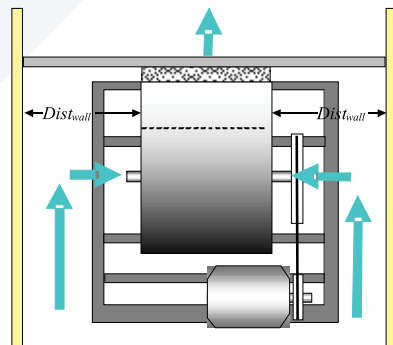

Fig. 26: Fan Inlet Spacing

In fact, the drive shaft is usually powered by an extended coupled shaft connected to a dynamometer, which not only drives the fans but also measures the power input. When fans are installed in actual equipment designs, where air flows change direction or are obstructed near the inlet of the fan, there are additional losses for which need to be accounted.

The spacing from the fan to an adjacent wall can be represented by the fraction of the fan wheel diameter. In Fig. 27, the loss coefficient associated with the fraction of a wheel diameter from the wall is shown.

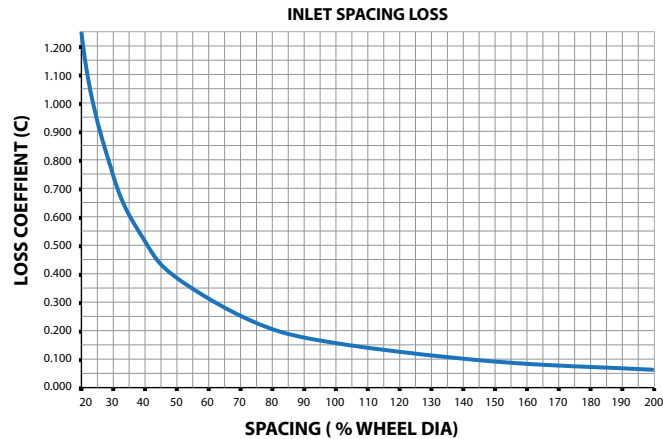

Fig. 27: Inlet Spacing Loss Coefficient

Example 4

GIVEN:

A forward curved 20" fan moving 10,000 cfm with an inlet velocity of 2012 FPM and the fan is spaced 10" from the wall on the non-drive side and 16" from the wall on the drive side.

FIND:

Inlet spacing loss coefficient and resulting pressure loss.

SOLUTION:

The non-drive side spacing is 50% while the drive side spacing is 80%. From Fig. 27, the loss coefficient for the non-drive side would be 0.4 and the loss coefficient for the drive side would be 0.2. The average loss coefficient would be 0.3.

$$P_v = \left(\frac{V}{4005}\right)^2 = \left(\frac{2012}{4005}\right)^2 = 0.252 \text{ in. wg}$$

$$\Delta P = P_v \cdot C = 0.252 \cdot 0.3 = 0.08 \text{ in. wg (Spacing Loss)}$$

For plenum fans with air entering axially, good practice is to maintain no more than a 45° approach angle between entering air streams and the inlet to the fan, as shown in Fig. 28. This inlet space is important for uniform air flow across the upstream component. Little, if any, inlet system effect occurs if it is 45° or closer.

Belt Guards

Belt driven fans usually include a belt guard. The belt guard covers only one side of a housed fan, as seen in Fig. 26, but greatly restricts and disrupts air flow into that fan inlet. Test data has revealed that an expanded metal belt guard has a loss coefficient of $C=1.17$. This value was derived by adding then removing a belt guard from fans in a test application.

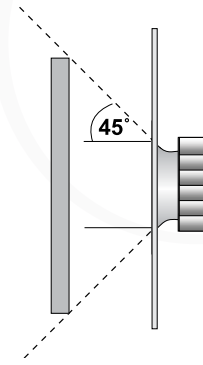

Fig. 28: Airstream Approach Angle

Example 5

GIVEN:

A forward curved 20" fan moving 10,000 cfm with an inlet velocity of 2012 FPM and the fan is spaced 10" from the wall on the non-drive side and 16" from the wall on the drive side.

FIND:

Belt guard pressure loss

SOLUTION:

$$\Delta P = P_v \cdot C = 0.252 \cdot 1.17 = 0.29 \text{ in. wg (Belt Guard Loss)}$$

Belts and Sheaves

Many fans used in HVAC applications are belt driven DWDI housed fans. The drives are located on the inlet of the housing. Since the fan is tested without the obstruction of the belts or sheaves, some additional loss must be considered. Since the size of the sheave and the design of the sheave vary greatly, there is no generalized single number loss coefficient. However, a generalized relationship derived from fan inlet blockage is shown in Fig. 29, representing loss coefficients based on free inlet area of a fan inlet.

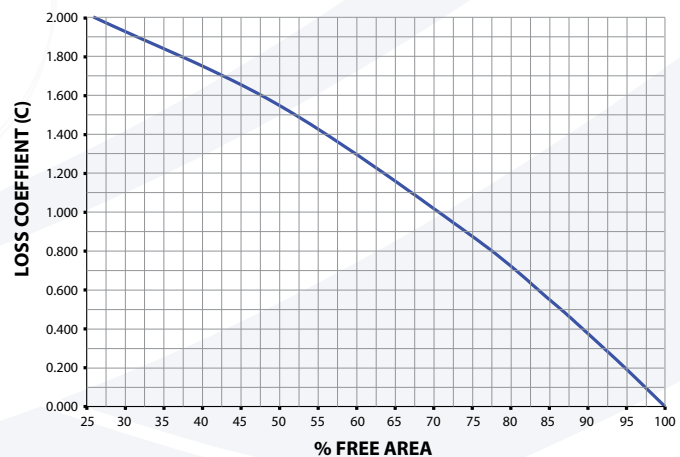

Fig. 29: Inlet Free Area Reduction Loss

Example 6

GIVEN:

A forward curved 20" fan moving 10,000 cfm with an inlet velocity of 2012 FPM and the fan is spaced 10" from the wall on the non-drive side and 16" from the wall on the drive side.

FIND:

The loss coefficient if a 6" solid sheave is used on the drive side of the fan.

SOLUTION:

Applying a 6" solid sheave the inlet blockage would be 9% (free area of 91%). From Fig. 29, this would give a loss coefficient of $C=0.35$ on one side or a net average of 0.175.

$$\text{Area of Circle} = \frac{\pi \cdot (\text{Diameter})^2}{4}$$

$$\text{Fan Inlet Area} = \frac{\pi \cdot (20 \text{ in.})^2}{4} = 314 \text{ in.}$$

$$\text{Shaft Area} = \frac{\pi \cdot (6 \text{ in.})^2}{4} = 28 \text{ in.}$$

$$\text{Blocked Area} = \frac{28 \text{ in.}^2}{314 \text{ in.}^2} = 0.09 = 9\%$$

$$\Delta P = P_v \cdot C = 0.252 \cdot 0.175 = 0.04 \text{ in. wg (Sheave Loss)}$$

Because the belt guard blocks air over the sheave, the corrections in this case should not be combined; only the belt guard should be used.

Fan Inlet Velocity Flow Probes

One common fan accessory is the double tube type inlet velocity flow measuring device. Testing has revealed that a set of probes, consisting of two 1/2" diameter sampling tubes, had a loss coefficient of $C=0.65$.

Example 7

GIVEN:

A forward curved 20" fan moving 10,000 cfm with an inlet velocity of 2012 FPM and the fan is spaced 10" from the wall on the non-drive side and 16" from the wall on the drive side.

FIND:

Pressure loss due to inlet probes.

SOLUTION:

$$\Delta P = P_v \cdot C = 0.252 \cdot 0.65 = 0.16 \text{ in. wg (Inlet Probe Loss)}$$

Combined Inlet Losses

In most cases, unless otherwise stated, these losses are additive. Using the double width fans and probes from the previous example, the following component losses can be calculated.

Example 8

GIVEN:

A forward curved 20" fan moving 10,000 cfm with an inlet velocity of 2012 FPM and the fan is spaced 10" from the wall on the non-drive side and 16" from the wall on the drive side and has a spacing loss of 0.08".

FIND:

Pressure loss with belt guard and inlet probe and pressure loss with sheave and inlet probe.

SOLUTION:

For 20" FC DWDI fan with belt guard and inlet probes only:

$$\Delta P = 0.08 + 0.29 + 0.16 = 0.53 \text{ in. wg}$$

For a 20" FC DWDI fan with only a sheave and inlet probes only:

$$\Delta P = 0.08 + 0.04 + 0.16 = 0.28 \text{ in. wg}$$

Elbows and Tees at Discharge

If ductwork is not extended straight from the discharge of a housed fan a distance equal to or greater than the effective duct length, additional system effect losses will need to be added.

If elbows or tees are installed in the ductwork at a distance downstream, less than the 100% effective duct length, then an additional fan system effect loss must be applied as indicated in Fig. 31. This loss is **in addition to the normal loss associated with an elbow or tee.**

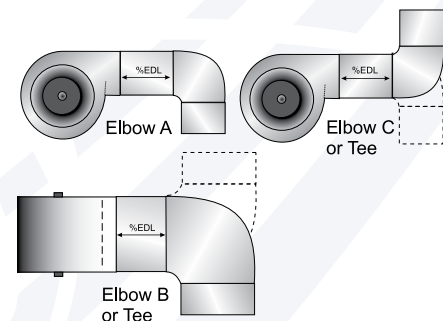

Fig. 30: Housed Fan Discharge Arrangements

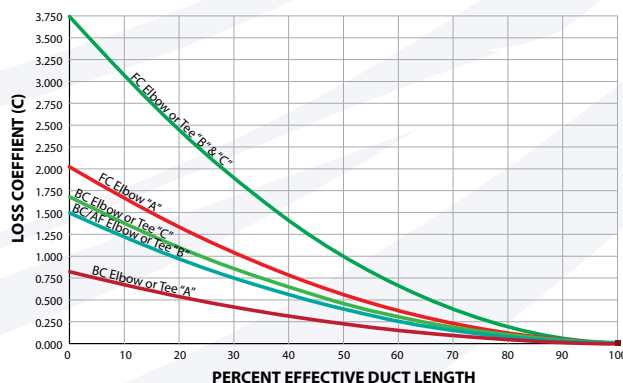

Fig. 31: Housed Discharge Elbows and Tee

Discharge Dampers

Dampers installed at the discharge of a fan can also have a dramatic effect on fan performance. For forward curved fans the dampers should be selected at 2 times the outlet velocity and for backward curve fans dampers should be selected at 1.25 times the outlet velocity. Blades on the dampers should always be vertical due to the uneven air flow profile at the fan outlet.

Unducted Discharge Losses

If the duct from a housed blower terminates at a plenum or open area with less than 100% of the effective duct length then the loss coefficients from Fig. 32 apply. In addition to the velocity pressure conversion losses incurred, the uneven velocity distribution and high spot velocity can have detrimental effects on the performance of down stream components. Components such as filters, coils and heaters are rated assuming a uniform flow profile.

Fig. 33 shows diffusion angles of a housed fan assuming a flow profile maintaining the range from peak spot velocity to edge velocity of less than 20%. Fig. 34 shows a fan with a conical type diffuser. Flat plate type blast diffuser plates have a similar effect. The loss coefficient for such a diffuser would be $C=0.57$ for a backward curved fan and $C=2.26$ for a forward curve fan. These diffuser losses are in addition to the unducted discharge loss.

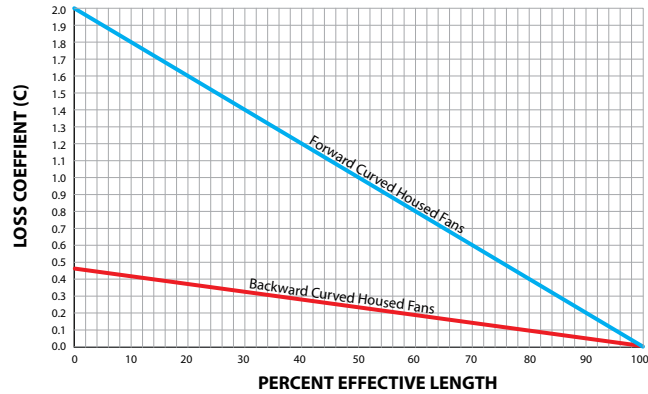

Fig. 32: House Fan Unducted Discharge Losses

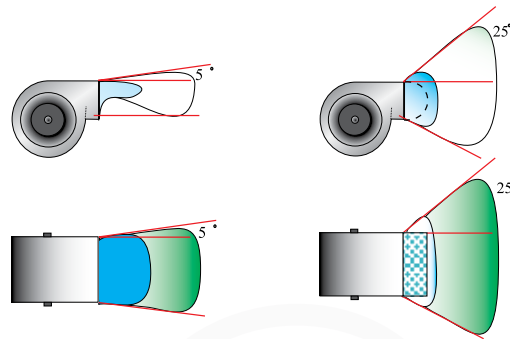

Fig. 33: Housed Fan Diffusion Angles

Fig. 34: Housed Fan with Conical Diffuser

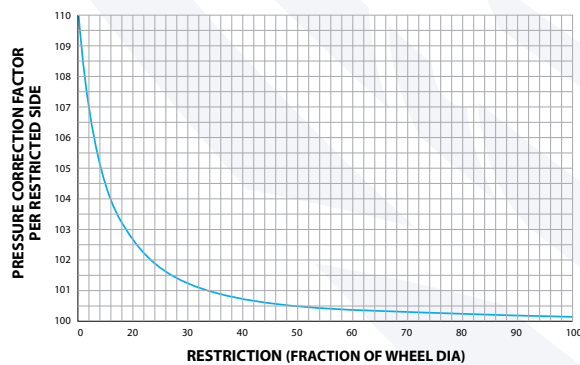

Fig. 35: Plenum Fan cfm Correction for Side Restriction

multiplier to the static pressure. Fig. 35 shows the pressure correction factor for a plenum fan restricted on one side.

These correction factors are additive. That is if one side is restricted such that a 2% increase in pressure is induced, another side to 2.5% and the top to 3% then the total correction is 7.5% added to the design static.

Plenum Fan Discharge System Effects

Plenum fans use unshrouded centrifugal fan impellers. The fans produce very little velocity pressure and are designed to pressurize a plenum. These type fans are an ideal choice for low velocity air streams such as those found in air handling applications. Since the outlet area is not constrained in the same way housed fans are, corrections for plenum fans are expressed as percent

Fan Efficiency

The use of static or mechanical fan efficiency as the sole judge of fan suitability or performance should be avoided. What is important is the minimum use of energy to supply the required airflow and pressure after all system effects and losses have been taken into account. As discussed in the previous section, different fans can have vastly different system effects. To fully analyze a fan, it must be understood how fan efficiency is calculated.

Fan Mechanical Efficiency

$$Eff = \frac{cfm \cdot Pressure}{Power} = \frac{\left(\frac{ft^3}{min}\right) \cdot \left(\frac{lb}{ft^2}\right)}{\left(\frac{ft \cdot lb}{min}\right)} = Dimensionless$$

Remember that 1 inch wg = 5.2 lb/ft² per inch wg. Motor power is often expressed in units of horsepower, not $\frac{ft \cdot lb}{min}$. Converting hp to $\frac{ft \cdot lb}{min}$ is a direct conversion 1 hp = 33,000 $\frac{ft \cdot lb}{min}$.

Inserting these two conversion constants back into the original efficiency equation yield:

$$Eff = \frac{\left(\frac{ft^3}{min}\right) \cdot \left(\frac{5.2 lb/ft^2}{in. wg}\right)}{\frac{33,000 \left(\frac{ft \cdot lb}{min}\right)}{hp}}$$

Forms of the equation can be reduced further to yield:

$$Eff = \frac{\left(\frac{ft^3}{min}\right)(in. wg)}{6346 \cdot hp}$$

Fan Static Efficiency

Static efficiency is similar to total efficiency. However it only considers the static pressure.

$$Eff_s = \frac{cfm \cdot P_s}{6346 \cdot bhp}$$

Static efficiency is often used to analyze fans that are applied to pressurize plenums. For all practical purposes plenum fan static efficiency and plenum fan mechanical efficiency are equal.

Fan Application Efficiency

Fan application efficiency is the ratio between power transferred to the airflow and the power used by the fan. Application efficiency adds the additional horsepower required to accommodate all applicable system effects and drive losses to brake horsepower. This allows the selection of a fan that will operate at the highest efficiency in a particular application. The fan application efficiency is independent of the air density and can be expressed as:

$$Eff_s = \frac{cfm \cdot P_s}{6346 \cdot bhp}$$

P_T is the total pressure produced, external to the fan, without including any system effects. System effects are reduction in fan performance, not changes in external static requirements.

The application brake horsepower (bhp_A) takes into account the additional horsepower required to overcome systems effects but does not contribute to useful work. It is found by:

$$BHP_A = \frac{bhp_{SE}}{eff_{Belts} \cdot eff_{Motor}}$$

bhp_{SE} is the brake horsepower of the fan selected at a static pressure including all system effect losses.

Typical Motor Efficiencies

Motor	Standard Efficiency	Premium Efficiency
2 hp	0.79	0.87
15 hp	0.90	0.93
40 hp	0.93	0.94

Belt efficiencies are similar in scale to motor efficiencies; belts on smaller motors have lower efficiencies while belts used with larger motors generally have efficiencies around 90-95% when first installed.

The majority of belt drives use V-belts. V-belts use a trapezoidal cross section to create a wedging action on the pulleys to increase friction and the belt's power transfer capability. Large horsepower V-belt drives will have a peak efficiency of 90% to 95% at the time of installation. However, efficiency deteriorates by as much as 5% (to a nominal efficiency of 85-90%) over time due to run in and tension loss as a result of stretching. Stretching produces belt slippage.

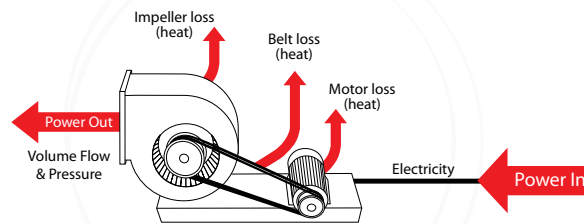

Fig. 36: Belt Driven Fan System

As the diagram shows, belt losses of slippage and heat are removed by using a direct drive configuration.

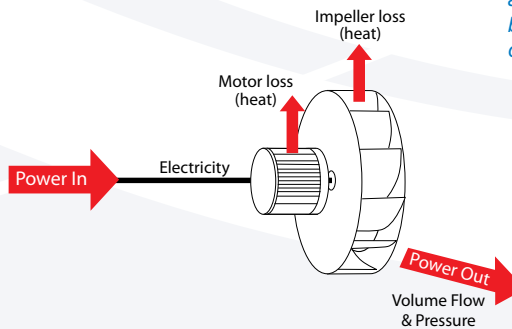

Fig. 37: Direct Drive Fan System

In addition to slippage, efficiency losses are due to wrapping losses as the belt is stretched and drawn around pulleys thus generating heat; smaller pulleys exacerbate these losses, and are less efficient.

When considering the efficiency of the fan system (Power Out ÷ Power In) there are multiple locations where power is lost in the conversion from electrical power in to fan power out. Fig. 36 shows a belt-driven, housed centrifugal fan system. It can be seen that losses stem from the motor, belt and impeller. Fig. 37 shows a direct drive system, it can be seen that belt losses are completely eliminated in this configuration.

When selecting fans for a particular application, the application efficiency is best used when comparing fan types.

Calculated Application Efficiency

	Motor Efficiency		Belt Efficiency		Fan Efficiency		System Effects		Total System Efficiency
Belt-Driven, Housed, Forward Curved Total Efficiency =	(0.90)	•	(0.87)	•	(0.60)	•	(0.70)	=	33%
Belt-Driven, Housed, Backward Curved Total Efficiency =	(0.90)	•	(0.87)	•	(0.75)	•	(0.80)	=	47%
Direct Drive, Unhoused Backward Curved, Total Efficiency =	(0.90)	•	(1.00)	•	(0.70)	•	(1.00)	=	63%

- Using the same 15hp motor in each example, the direct drive, backward curved fan is 91% more efficient than the belt driven, housed forward curved fan. It is 34% more efficient than the belt driven, housed backward curved fan.

Example 9

GIVEN:

An application requiring 3,000 cfm at 2" wg of static pressure blowing into a plenum through a gas heater located 18" downstream.

FIND:

Velocity pressure, system effect losses and required brake horsepower.

SOLUTION:

The initial selection of a FC fan yields a 12" fan with an inlet velocity of 1,705 FPM and an outlet velocity of 2,083 FPM requiring 1.6 bhp operating at 67.6% mechanical efficiency.

$$P_v = \left(\frac{V}{4005} \right)^2 = \left(\frac{1705}{4005} \right)^2 = 0.18 \text{ in. wg}$$

Assuming this fan will require a 4" diameter sheave on one side of the inlet (89% free area). The loss coefficient for 89% free area is C=0.40 for one side or an average of C=0.20.

$$\Delta P = P_v \cdot C = 0.18 \cdot 0.20 = 0.036 \text{ in. wg}$$

The blow through application for the heater will require an unducted discharge. The loss coefficient for unducted discharge of a FC fan is $C=2$.

$$P_v = \left(\frac{V}{4005}\right)^2 = \left(\frac{2083}{4005}\right)^2 = 0.27 \text{ in. wg}$$

$$\Delta P = P_v \cdot C = 0.27 \cdot 0.20 = 0.54 \text{ in. wg}$$

For even distribution over the heater, a diffuser will be required. The loss coefficient for a diffuser is $C=2.26$.

$$\Delta P = P_v \cdot C = 0.27 \cdot 2.26 = 0.61 \text{ in. wg}$$

The total system effect is:

$$\Delta P_{SE} = 0.036 + 0.54 + 0.61 = 1.19 \text{ in. wg}$$

This gives us a new fan duty of:

$$\Delta P_T = 2.0 + 1.19 = 3.19 \text{ in. wg}$$

Reselecting the fan for 3.19" wg gives us 2.3 bhp. The application brake horsepower would be:

$$BHP_A = \frac{bhp}{eff_{Belts}} = \frac{2.3}{0.75} = 3.1 \text{ bhp}$$

The applications efficiency would be:

$$Eff_A = \frac{cfm \cdot P_T}{6346 \cdot bhp_{SE}} = \frac{3000 \cdot 3.19}{6346 \cdot 3.1} = 49.2\%$$

Selecting a direct drive backward curve plenum fan for the same application gives an 18" fan requiring 1.6 bhp and operating at 57.3% static efficiency. No system effects are imposed in this application so the system effect static pressure equals the required static pressure.

$$BHP_A = \frac{bhp}{eff_{Belts}} = \frac{1.6}{1.00} = 1.6 \text{ bhp}$$

The application efficiency would be:

$$Eff_A = \frac{cfm \cdot P_T}{6346 \cdot bhp_{SE}} = \frac{3000 \cdot 2}{6346 \cdot 1.6} = 59.1\%$$

In this case, where the application is unducted pressurization of a plenum, the plenum fan operated at a reduced horsepower and much higher application efficiency.

HVAC System Energy Efficiency

The U.S. Department of Energy has published a three-volume set of reports on energy consumption in commercial building HVAC systems in the United States. The second of the three volumes focuses on the energy required to distribute heating and cooling within a building, reject to the environment the heat discharged by cooling systems, and move air for ventilation purposes. Energy used for these purposes in commercial building HVAC systems accounts for about 10% of all annual primary energy usage for the commercial sector.

Fig. 38 shows the breakdown of this energy use by equipment type. Most of the energy is associated with fans, either the supply and return fans of air handling units, or the exhaust fans used for ventilation. Combined supply, return and exhaust fans count for 83% of the power consumed by HVAC auxiliary equipment.

Supply fans use much of the energy because (1) supply fans are used in virtually 100% of HVAC system types, (2) typical air distribution design practice involves considerable pressure drop for filtration, cooling and heating coils, terminal boxes, and diffusers, and (3) many of these fans operate at 100% power during all building occupied periods.

When evaluating the efficiency of HVAC equipment some owners and engineers only consider the overall Air-Conditioning, Heating, Refrigeration Institute (AHRI) listed equipment Energy Efficiency Ratio (EER), which is provided only at standard AHRI operating conditions.

The external static pressure of the AHRI conditions is lower than is commonly encountered in realistic building applications. This minimizes the effect of fan energy in this rating. The EER of HVAC equipment is a ratio calculated by dividing the cooling capacity output in Btu's per hour (Btu/hr) by the equipment power input in watts for a given set of rating conditions. While this is an important metric, many commercial buildings utilize economizers, have heating cycles that do not utilize compressors, and operate with ventilation modes where the fan continues to operate although the mechanical cooling system requirements have been reduced or eliminated.

The hours of operation for reduced or no mechanical cooling often exceed the time in which the full mechanical cooling system is in operation. Therefore, the EER value used for equipment selection is only valid for a very limited number of hours throughout the year. An understanding of fan efficiency and operation has led many to consider both the EER and fan system efficiency when making HVAC equipment selections.

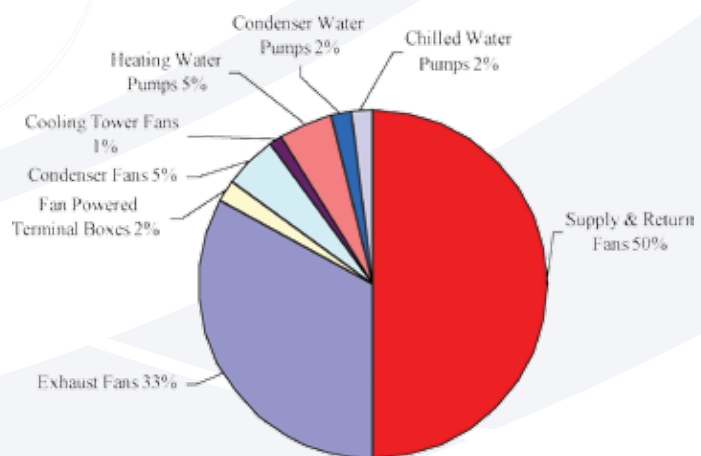

Fig. 38: Energy Usage by Auxiliary HVAC Equipment Category

Variable Air Volume and Constant Volume Fan Control Schemes

One of the factors affecting the power consumed by the fan and motor depends on the type of control system selected for the HVAC equipment. The two most common systems are the VAV system and the Constant Volume (CV) system. Both the CV and VAV systems can employ many types of impeller design.

Variable Air Volume Systems

In a VAV system, variations in the thermal requirements of a space are satisfied by varying the volume of air that is delivered to the space at a constant temperature. Typically, these systems are more efficient since (1) less energy is used for cooling because the volume of air cooled is reduced and (2) fan energy is reduced because the amount of air the fan needs to move is reduced. With a high efficiency fan, the benefits of this control system can be maximized. VAV control can also be applied to exhaust and return air streams in a VAV system to balance the building static at the various operating conditions.

Constant Volume Systems

The most commonly applied air distribution system is a constant volume, single-zone system with one thermostat in an "average" location controlling the air delivered to every room. Packaged air conditioning units of all sizes are available as constant volume, single zone units. As the name implies, variations in the thermal requirements of a space are satisfied by varying the temperature of a constant volume of air delivered to the space or cycling the unit on and off. Fan energy used by constant volume systems is generally greater than variable air volume systems. Because of this, including high efficiency fans on a CV system can have a pronounced effect on the overall efficiency of a CV system.

System Efficiency Example

In Fig. 39, a single stage vapor compression cycle shows energy being transferred to the refrigerant as the fan causes warm air to pass over the evaporator coil containing the cool refrigerant. The compressor also adds energy to the refrigerant by compressing the refrigerant to a high pressure. The condenser rejects the energy added to the refrigerant by the evaporator and compressor.

The importance of selecting efficient fans can be seen by applying values to the components shown in Fig. 39.

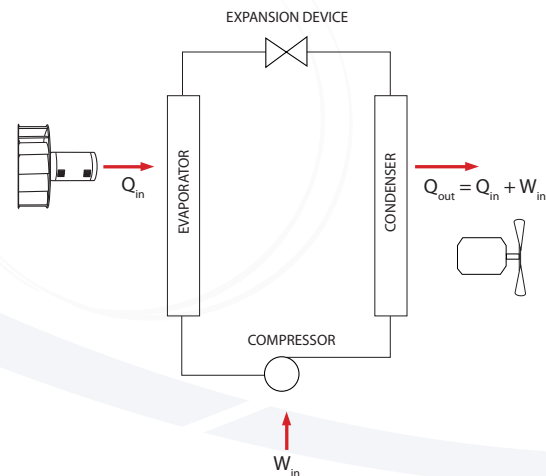

Fig. 39: Vapor Compression Cycle

Example 10

GIVEN:

Assume the single stage vapor compression cycle shown in Fig. 39 has 26 tons of capacity, or 312,000 Btu/hr. Assume that the compressor operates with an EER of 15.4. Remember that the EER is a ratio calculated by dividing the cooling capacity output in Btu's per hour by the power input in watts. Therefore, the 312,000 Btu/hr of capacity divided by 15.4 Btu/(Watt • hr) yields that the power input to the compressor (W_{in}) must be equal to 20,260 W, or 69,130 Btu/hr. Assume the constant volume airflow generated by the fan is 10,000 cfm and the total static pressure is 2.5 in. wg.

FIND:

The fan and compressor power usage.

SOLUTION:

Using the AAON fan selection software, multiple backward curved fan arrays are shown that can accommodate these conditions. For this example, a backward curved fan array operating at a total of 8.3-brake horsepower (bhp) was selected. A fan requirement of 8.3 bhp, attached to motors operating at 90% efficiency, would require input power of 23,465 Btu/hr.

Power Utilization Summary

	Btu / hr	Watt	Horsepower	Ton
System Capacity	312,000	91,438	122.6	26.0
Compressor Input Power	69,130	20,260	27.2	5.8
Backward Curved Plenum Fan Power	23,465	6,876	9.2	2.0

At full load conditions, the compressor will consume 69,130 Btu/hr while the fan consumes 23,465 Btu/hr. From these numbers, and the understanding that fan operating hours often exceed mechanical cooling operating hours, one can begin to see that the **fan power can match, or even exceed, compressor power for many applications**. For this reason fan efficiency should be carefully reviewed when selecting HVAC equipment.

Continuing with the same constant volume illustration, with the following basic operating assumptions, assume that:

5% of the unit's operation requires one hundred-percent mechanical cooling capacity,

20% of the unit's operation is in heating mode,

30% of the unit's operation is in an "unoccupied" mode that requires ten-percent mechanical cooling capacity

45% of the time the machine is at a part load requiring an average fifty-percent mechanical cooling capacity.

100%

Fan and Compressor Power Consumption			
Peak Cooling Mode	Btu/hr	Watt	Horsepower
Compressor Input Power	69,130	20,260	27.2
Backward Curved Plenum Fan Power	23,465	6,876	9.2
Heating Mode	Btu/hr	Watt	Horsepower
Compressor Input Power	0	0	0
Backward Curved Plenum Fan Power	23,465	6,876	9.2
Unoccupied Mode	Btu/hr	Watt	Horsepower
Compressor Input Power	6,913	2,026	2.7
Backward Curved Plenum Fan Power	23,465	6,876	9.2
Part Load	Btu/hr	Watt	Horsepower
Compressor Input Power	34,565	10,130	13.6
Backward Curved Plenum Fan Power	23,465	6,876	9.2
Weighted Average Operating Fan and Compressor Power Consumption			
Part Load	Btu/hr	Watt	Horsepower
Compressor Input Power	21,085	6,179	8.3
Backward Curved Plenum Fan Power	23,465	6,876	9.2

It can be seen from the example that the compressor power is nearly 3 times the fan power at peak load and the average power for the fan over all operating modes of the unit exceeds the compressor power. As discussed previously, the direct drive, backward curved, plenum fan system is one of the most efficient systems available; a belt driven, forward curved, housed fan system's power would exceed the power by an even greater amount, for the same example conditions. In addition, higher efficiency direct expansion (DX) units, such as those with water-cooled or evaporative-cooled condensers, would further demonstrate the importance of selecting efficient fans, because the high efficiency DX system would consume less power than shown in the example.

AAON Direct Drive Backward Curved Plenum Fans

AAON offers fan arrays configurable from one to four, direct drive, backward curved, plenum fans in a frame assembly. By offering combinations of varying fan widths and diameters, the fan(s) can be selected at optimum operating efficiency. The variety of width-to-diameter ratios improves operating savings because the best possible fan can be selected and applied in the system. The choices of fan quantity, width and diameter provide several additional advantages over units constructed with only an option for housed fans that are belt driven by a single large motor. The use of direct drive motors improves on the belt driven design by increasing the fan system efficiency, preventing belt vibration, reducing noise and eliminating belt wear. It also requires less service attention than the belt and pulley assembly, increasing unit uptime and reducing required maintenance hours. Vibration isolated fan assemblies prevent fan vibration from being transmitted to the occupied space through the equipment base.

Blow-Through Designs

Since many applications require air handling units to blow-through a downstream component (such as heaters, final filters or coils) the plenum fan's lower outlet velocity and uniform air distribution allows for more even air flow through these components while avoiding discharge system effects. The axial inlet air flow arrangement of plenum fans also avoids most inlet system effects. With no need to drive the fan at the fan inlet, blockage losses are also avoided. Additionally, the unhooded, backward curved impeller discharging into a plenum is quieter than a hooded impeller that blows directly into the duct, with the pressurized plenum acting to attenuate unwanted noise.

Blow-through coil configurations are particularly effective in lower leaving air temperature designs, especially in dehumidification applications. In a blow-through coil design the fan motor heat is added before the cooling coil instead of after the cooling coil, as is the case of a draw-through application, allowing for a lower leaving air temperature and dew point. Hooded fans are not as easily adapted to the blow-through position, because hooded fans add high velocity to the air, which may not be suitable for downstream elements such as filters and coils. Caution should be used with blow-through coil designs without any reheat to avoid downstream final filter condensation.

Application Flexibility

By featuring the direct drive plenum fan, AAON is able to offer several additional advantages. Application space can be saved by reducing the length required over comparable hooded fans, which can require several feet of straight ductwork to achieve the proper velocity profile to deliver conditioned air to the space. In addition, the plenum fan allows the supply location to be at any, of up to five discharge locations (top, bottom, left, right and end); the straight ductwork needed to efficiently apply hooded fans will not accommodate such variety. Elbows and tees can also be located close to the unit takeoff without incurring the system effect losses and excess noise generation seen with hooded fans without long straight runs on the discharge.

Multiple Fan Redundancy

Having more fans operated by smaller motors makes motor replacement more convenient for service personnel, who might alternatively require special equipment to remove and replace a single large, heavy motor. Smaller motors are usually available from local sources more readily than larger motors. In addition, the high frequency sound of small fans is easier to attenuate than the low frequency sound of a large fan. Because the fan array with smaller fans has less low frequency sound energy, no sound traps or shorter, less costly sound traps may be needed to attenuate the higher frequency sound produced by the plurality of fans. The use of a backward curved fan array, rather than a single large fan, also offers redundancy capabilities and more even air flow to downstream components. In the AAON backward curved plenum fan array, if a motor becomes inoperable, with the closing of its back draft damper or blanking off of the fan inlet, substantial uninterrupted airflow can usually be achieved through the remaining fans. When an inoperable fan condition occurs, the unit controller can sense the drop in static pressure and instruct the remaining VFD to increase the speed of the remaining motors to provide the desired airflow. This capability prevents an unscheduled loss of unit operation; instead, the remaining fans continue to operate until the unit can be scheduled for service.

Advanced Selection Tools

The AAON fan selection software considers input criteria such as airflow and static pressure and then outputs the fan array combinations that will successfully meet the input requirements. From the fan summary screen, the user may pick the optimum selection for the given application. Fan performance information is provided regarding the quantity of fans, brake horsepower requirements, operating efficiency and sound power levels. Unlike selection software that lists only one fan option for a given size unit, AAON selection software gives the user the ability to pick from multiple combinations so that the fan system selected best fits their needs.

The AAON array of backward curved plenum fans, offers improved efficiency, quieter operation, superior uptime, a smaller footprint, and greater flexibility than comparable air moving devices in the HVAC industry.

To specify these products for an application, or to learn more about ways AAON can provide heating and cooling solutions for you, contact your local AAON Sales Representative.



References

ADL, 1999b, “Energy Consumption Characteristics of Commercial Building HVAC, Systems Volume II: Thermal Distribution, Auxiliary Equipment, and Ventilation.” Final, Report for the U.S. Department of Energy, Office of Building Technology, State and Community Programs.

ASHRAE. HVAC Systems and Equipment Handbook. Atlanta: ASHRAE, 2000.

Meyer, Leo A. (2002). Fans and V-Belt Drives. Hayward, CA.:LAMA Books.

SMACNA. HVAC Systems Duct Design. Vienna, VA 1990.

AMCA 99, Standards Handbook, Arlington Heights, IL, 2003

AMCA 201 Fans and Systems, Arlington Heights, IL, 2002

ANSI/ASHRAE Std. 51, ANSI/AMCA 210 Laboratory Methods of Testing Fans for Certified Aerodynamic Performance Ratings, Arlington Heights, IL 2007



Defining Quality. Building Comfort.

2425 S. Yukon Ave. • Tulsa, OK 74107 • (918) 583-2266

ValueAir • R60140 • 110103