



Sequence of Operations
February 14, 2018

Jerry Cohen
President
Jacco & Assoc.

Who is Jacco

2018 Seminars

March 14th - Applying Natural Gas, Water Cooled & Air Cooled Modular Chilled Water Systems

June 13th - Best Practices for DX Piping

September 12th - Applying Adiabatic and Steam Humidification Systems

December 12th - Applying Low Dewpoint OA Systems using DX & Desiccant Technology



Problem Job Project Action Levels

Level 1

Description: Problems are found during startup and Service Technician is able to repair them onsite.

Costs: Covered under startup pricing.

Lead: Service department.

Support: None required.

Action: Repair item, check to make sure everything works properly. Service Technician looks at project/application to foresee and eliminate any potential Level 3 problems.

Level 2

Description: Problems are found during startup or during the first 30 days of operation. Parts and/or labor will require manufacturer warranty authorization and/or have to be ordered for installation at a later date.

Costs: Costs not covered by warranty parts/labor authorization are to be covered by the Systems Sales department and charged to the project.

Lead: Service department.

Support: None required.

Action: Contact factory for warranty labor/parts authorization. Notification of problem to Systems Sales Engineer and installing Mechanical Contractor within 24 hours to include tentative repair timeframe based upon parts availability.

Level 3

Description: Level 2 resolution does not work. Problems occur outside of first 30 days after startup. Mechanical Contractor and/or End User are involved. Problem may be re-occurring. Level 3 can be initiated by anyone at Jacco & Associates.

Costs: Costs not covered by warranty parts/labor authorization are to be covered by the Systems Sales department and charged to the project. Service will take the lead on costs incurred that should be covered by the manufacturer.

Lead: Whoever designates the project a Level 3.

Support: Collective intelligence to include Systems Sales & Service.

Action: Lead person sends email to JKC, GAD and SML announcing project is Level 3. Collective intelligence gathering to correctly diagnose problem. Contact factory for warranty labor/parts authorization, potential factory Service Technician site visit. Include in Problem Job List

Closing: After completion have an action/project review internally to include costs, responsibility, improvement of processes to avoid similar instances in future. Follow up with Architect/Engineer and End User to insure customer satisfaction with the operation of the unit.

Level 4

Description: Problems occur outside of first 30 days after startup. Mechanical Contractor and/or End User are involved. Problem is re-occurring after multiple site visits by Service Technicians. Jacco ownership is involved. Manufacturer is involved.

Costs: Cost is not the issue, purpose drives the completion.

Lead: Whoever designates the project a Level 4.

Support: Collective Intelligence to include Systems Sales and Service.

Action: Lead person sends email to JKC, GAD & SML announcing project is Level 4. Perform any and all actions that can resolve the problem and keep the owner operating in the interim. Collective intelligence gathering to correctly diagnose problem. Include in Problem Job List

Closing: After completion have an action/project review internally to include costs, responsibility, improvement of processes to avoid similar instances in future. Personal Customer Review with Architect/Engineer and End User to insure customer satisfaction with the operation of the unit. Project does not come off of Problem List until the Personal Customer Review is complete and costs are delegated.

Special Note:

Everyone can offer to send a service technician to any project at any time. If it is Jacco/Manufacturer problem then there is no charge, if it is a project problem then Jacco will invoice customer.



Recommendations

- Move the sequence of operations up to the schematic design phase!
- Keep it simple! Swing to balance!
- Let the commissioning agent and TCC do their job!

Process Elements

- List Systems To Be Controlled
- List Modes, Components & Sub-Components
- Write Simple Sequence
- Cartoon
- Add Points To Cartoon
- Final Points List

List Modes

- Modes:
 - Occupancy
 - Cooling
 - Heating
 - Outside Air
 - Building Pressure
 - Humidification
 - Dehumidification

List Components

- Components:
 - Cooling
 - Heating
 - Supply Fan
 - Return/Exhaust Fan
 - Dampers
 - Reheat
 - Humidifiers

List Sub-Components

- Cooling
 - DX, Chilled Water
 - Staged, Modulating
- Heating
 - Gas, Electric, Hot Water, Steam, Heat Pump
 - Staged, Modulating
- Supply Fan
 - Constant, Variable
- Return/Exhaust Fans
 - Constant, Variable
 - Building Pressure
- Control Dampers
 - AFMS, Economizer, OA, RA
- Reheat for Dehumidification
- Humidification
 - Steam, Adiabatic

Your Home

Let's Write a Sequence!

Your Home

- Modes:
 - Occupancy
 - Cooling
 - Heating
 - Humidification

Your Home

- Components:
 - Cooling
 - Heating
 - Supply Fan
 - Humidifiers

Your Home

- Sub-Components:
 - Cooling
 - 1 Stage DX
 - Heating
 - 2 Stage Gas
 - Supply Fan
 - Constant Volume
 - Humidification
 - Adiabatic

Your Home

- Cooling on with call from space thermostat
 - Stage as required to maintain 75F adj.
- Heating on with call from space thermostat
 - Stage as required to maintain 70F adj.
- Fan on with call for heating or cooling
 - Auto/On
- Humidification on with call from space/return air humidistat
 - Stage as required to maintain 30% RH adj.
- Unoccupied mode to maintain 55 heating or 85 cooling adj.

Constant Volume

- Cooling on with call from space thermostat
 - Stage as required to maintain 75F adj.
- Heating on with call from space thermostat
 - Stage as required to maintain 70F adj.
- Fan on with call for heating or cooling
 - Auto/On
- Humidification on with call from space/return air humidistat
 - Cycle as required to maintain 30% RH adj.
- Unoccupied mode to maintain 55 heating or 85 cooling adj.
- First stage of cooling shall be outside air if available through enthalpy controlled economizer

CAV p1

Constant Air Volume (CAV)

Mode Enable Sensor Options

The temperature of this sensor will determine if the unit is in heating, cooling or vent mode during occupied operation. The following options are available:

- Space Air Temperature Sensor (CAV,)
- Return Air Temperature Sensor (CAV)

Occupied Operation

There are several ways to initiate the Occupied mode of operation for the VCM-X:

- Internal week schedule
- Remote Forced Occupied contact closure
- Pushbutton Override button on a Space Sensor (Override length is user adjustable)
- Monitoring an external Orion scheduling device

Scheduling

- Has an internal clock that provides 7 day scheduling with 2 start/stops per day.
- Allows scheduling of up to 14 holiday periods per year.

Unoccupied Operation

- The space sensor uses Night Setback Setpoints for heating and cooling calls. If Night Setback Setpoints are left at the default 30°, no Night Setback operation will occur and the unit will be off.
- Uses normal dehumidification setpoint for unoccupied dehumidification calls if Night Humidity Control is configured.
- Outdoor air damper will be closed except if unit is in unoccupied economizer free cooling mode.
- If there is no call for heating, cooling or dehumidification the unit will be in the Off Mode
- If this is a MUA unit that also has return air function, the unit can be configured to operate as a CAV unit in the Unoccupied Mode using space temperature night setbacks and/or a space dehumidification setpoint (See MUA Unoccupied Night Setback Operation section). The outside air damper remains closed. Otherwise the MUA unit will remain off in the Unoccupied Mode.

HVAC Modes of Operation

There are 6 possible HVAC Modes of Operation:

- *Cooling
- *Heating
- *Ventilation
- *Off

Cooling Mode with Digital Scroll Compressor and Optional Fixed Capacity Scroll Compressors

- Cooling is enabled when the temperature at the Mode Enable Sensor rises one deadband above the Cooling Setpoint. Cooling is disabled when the Mode Enable temperature falls one deadband below the Cooling Setpoint. The setpoint and deadband are user adjustable.
- Under normal VAV operation (Supply Air Control), the unit is in Cooling Mode anytime it is in the Occupied Mode.
- In the cooling mode, as the Supply Air Temperature (SAT) rises above the Active Supply Air Cooling Setpoint (see Supply Air Temperature Setpoint Reset section for explanation), the Digital Compressor will stage on and modulate to control to the Active Supply Air Cooling Setpoint.
- If additional cooling is required, fixed compressor stages can be staged on while the Digital Compressor continues to modulate.
- To stage up the extra compressor(s), the SAT needs to be above the Active Supply Air Cooling Setpoint and the Digital Compressor needs to be at 100% for a period of time equal to the Stage Up Delay. Once a fixed compressor is enabled the digital compressor signal will go to 10% and modulate up as needed. This will repeat as additional fixed compressors are staged up.



CAV p2

- For compressors to stage on, Minimum Off Times (adj.) must be satisfied as well as Stage Up Delays (adj.).
- To stage down the extra compressor(s), the SAT needs to be below the Active Supply Air Cooling Setpoint minus the Cooling Stage Control Window and the Digital Compressor needs to be at 0% for a period of time equal to the Stage Down Delay. Once a fixed compressor stages off the digital compressor will go to 100% and modulate down as needed. This will repeat as additional fixed compressors stage off.
- For compressors to stage down, Minimum Run Times (adj.) must be satisfied as well as Stage Down Delays (adj.). The digital compressor is always the last compressor to be deactivated.
- Mechanical cooling is disabled if the outdoor air temperature (OAT) falls 1° below the Cooling Lockout Setpoint and will remain disabled until the OAT rises 1° above the Cooling Lockout Setpoint. If the OAT disables mechanical cooling while it is currently operating, mechanical cooling will stage off as minimum run times and stage down delays are satisfied.
- If the economizer is enabled it will function as the first stage of cooling (see Economizer section).
- If this is a DPAC unit, the Return Air Bypass Damper remains closed during the cooling mode.

Heating Mode:

- Available heating option is Modulating Gas Heat.
- Heating is enabled when the temperature at the Mode Enable Sensor falls one deadband below the Heating Setpoint. Heating is disabled when the Mode Enable temperature rises one deadband above the Heating Setpoint.
- Once in the Heating Mode the unit will stage or modulate heating to maintain the Supply Air Temperature at the **Active Supply Air Heating Setpoint** (See Supply Air Temperature Setpoint Reset section for explanation).
- Multiple stages of heating can be configured subject to user adjustable minimum run times, minimum off times, staging up and staging down delays.
- Mechanical heating is disabled if the outdoor air temperature (OAT) rises 1° above the Heating Lockout Setpoint and will remain disabled until the OAT falls 1° below the Heating Lockout Setpoint. If the OAT disables mechanical heating while it is currently operating, mechanical heating will stage off as minimum run times and stage down delays are satisfied.

Ventilation Mode:

- This is only available in the Occupied Mode of operation on units configured for continuous fan operation and is generated anytime there is no demand for heating or cooling.

Off Mode:

- Occurs in the Unoccupied Mode when there is no heating, cooling or dehumidification demand.
- Can only occur in the Occupied Mode if the fan is configured to cycle with heating and cooling and there is no call for heating, cooling or dehumidification.
- Supply fan is off and the outside air damper is closed.

Economizer Operation

- Enabled when Outdoor Air (OA) drybulb or wetbulb temperature falls below the Economizer Enable Setpoint by 1° and the OA temperature is at least 5° below the return air temperature (if a return air temperature sensor is being used).
- Economizer operation is disabled when the OA temperature rises 1° above the Economizer Enable Setpoint.
- Wetbulb operation requires an Outdoor Humidity Sensor.
- Economizer acts as 1st stage of cooling and controls to the Active Supply Air Cooling Setpoint. If the economizer reaches 100% and the supply air temperature is still above setpoint, mechanical cooling is allowed to stage up while the economizer is held at the full open position.
- An Economizer Minimum Position can be programmed into the controller.
- A Economizer Damper is closed during Unoccupied Mode, except when unoccupied free cooling is used during night setback operation.



CAV p3

Space Sensor Operation

- Available as a Plain Sensor, Sensor with Override, Sensor with Setpoint Slide Adjust, and Sensor with Override and Setpoint Slide Adjust.
- Sensors with Setpoint Slide Adjust can be programmed to allow space setpoint adjustment of up to $\pm 10^{\circ}$ F.
- The Setpoint Slide Adjust will adjust the setpoints of whichever sensor is the mode controlling sensor, even if that sensor is not installed Space Temperature Sensor.
- If Space Temperature is being used to reset the Supply Air Temperature Setpoint, then the Slide Adjust will adjust the HVAC Mode Enable setpoints and the SAT/Reset Source setpoints simultaneously.
- For MUA applications the Space Sensor can be used as a reset sensor to reset the Supply Air Setpoint based on space conditions.
- During Unoccupied hours the Override Button can be used to force the unit back into the Occupied Mode (by pressing the button for less than 3 seconds) for a user-defined override duration of up to 8.0 hours. Pressing the button between 3 and 10 seconds cancels the override.

Supply Fan Operation

- Occupied Mode – Supply fan can be configured to run continuously (default) or to cycle with heating, cooling or dehumidification.
- Unoccupied Mode – Supply fan will cycle on a call for heating, cooling or dehumidification.
- Anytime the Supply Fan is requested to start, a 1 minute minimum off timer must be satisfied. If the timer is satisfied the Supply Fan relay is activated while all other outputs are held off for a period of 1-2 minutes to purge stagnate air from the ductwork before heating or cooling occurs.
- In fan cycle mode or when going unoccupied the supply fan is held on for 2 minutes after the last stage of heating or cooling stages off.

Dirty Filter Status

This input in uses a 24 VAC wet contact closure for Filter Status Indication. A differential pressure switch (by others) is required.

Duct Static Pressure Control for Filter Loading

- In order to maintain a constant CFM through the supply air ducts on MUA Unit or a mixed air CAV, PAC or DPAC Unit, a duct static pressure sensor can be used to monitor the discharge pressure.
- If the filters are getting dirty, the VCM-X will ramp up the VFD to compensate for the decrease in airflow.
- To utilize this feature the unit must be configured to use VFD fan control.
- This feature cannot be used if this is a VAV Unit with typical duct static pressure control.

Remote Forced Heating and Cooling

- These inputs (24 VAC wet contacts) allow another control system or a thermostat to force the unit into heating or cooling.
- To utilize these inputs, the heating and cooling setpoints in the VCM-X must be set to zero.
- Once in this force mode the unit will stage heating/cooling to maintain the appropriate heating/cooling leaving air setpoint until the force is removed.

Emergency Shutdown

- A 24 VAC wet contact input is available to be used with a N.C. Smoke Detector, Firestat, or other shutdown condition (all by others).
- If this contact opens it will initiate shutdown of the VCM-X and will generate an alarm condition. This contact closure does not produce an instantaneous shutdown.



CAV p4

Temperature Protection:

- Activated when the Supply Air Temperature (SAT) rises above the High Cutoff Temperature (immediate) or drops below the Low Cutoff Temperature (for 10 minutes) both of which are user adjustable. This mode shuts off the unit (with a 3 minute fan off delay) until the mode is cancelled.
- This mode is cancelled when the SAT drops 5 degrees below the High Cutoff Temperature Setpoint or rises 5 degrees above the Low Temp Cutoff Temperature Setpoint, or when the unit changes back into Occupied Operation.

Outdoor Air Lockouts

- Mechanical cooling is disabled when the Outdoor Air Temperature is below the Cooling Lockout Setpoint.
- Mechanical heating is disabled when the Outdoor Air Temperature is above the Heating Lockout Setpoint.
- For Air to Air Heat Pumps the Cooling Lockout also applies to Compressor Heating, so it will usually be a lower setting than on Cooling units that are not Air to Air Heat Pumps.

VCM-X Controller and Expansion Boards I/O Map

I/O Map

VCM-X Controller			
	Analog Inputs	Analog Outputs	Relays
1	Space temperature	Economizer	Supply Fan
2	Supply Temperature	Supply Fan VFD	Configurable
3	Return Temperature		Configurable
4	Outdoor Temperature		Configurable
5	Coil Temperature		Configurable
6	Static Pressure		
7	Space Sensor Slide Offset or Remote BAS Reset of SAT Setpoint		
VCM-X Expansion Module			
	Analog Inputs	Analog Outputs	Binary Inputs
1	Outdoor Humidity	Building Pressure VFD	Emergency Shutdown
2	Space/RA Humidity	Modulating Heating	Dirty Filter
3	Not Used	Modulating Cooling	Proof of Flow
4	Building Pressure	Return Air Damper	Remote Forced Occupied
5		Return Air Bypass Damper	Remote Forced Heating
6			Remote Forced Cooling
7			Exhaust Hood On
8			Remote Forced Dehum.
4 Binary Input Expansion Module			
	Binary Inputs		
1	Emergency Shutdown		
2	Dirty Filter		
3	Proof of Flow		
4	Remote Forced Occupied		
12 Relay Output Expansion Module			
	Relay Outputs		
1-12	Configurable		

Economizer Operation

- Enabled when Outdoor Air (OA) drybulb (enthalpy) temperature falls below the setpoint less offset
- Economizer operation is disabled when the OA temperature rises above the setpoint plus offset.
- Economizer acts as 1st stage of cooling and controls to the Cooling Setpoint. If the economizer reaches 100% and the temperature is still above setpoint, mechanical cooling is allowed to stage up while the economizer is held at the full open position.
- Comparative economizer requires RA sensors and compares OA to RA to use the most advantageous airstream to cool.
- Economizer Minimum Position can be controlled with an AFMS.
- Economizer Damper is closed during Unoccupied Mode, except when unoccupied free cooling is used during night setback operation.

Unoccupied

- During the unoccupied mode the fan shall be disabled and the economizer dampers shall be in the full return position. The unit shall remain in the unoccupied mode until commanded to the warm-up, cool-down, or occupied mode. (EMS, Thermostat, VAV)
- During the unoccupied heating mode the supply fan shall be enabled. The economizer dampers shall remain in the full return position. The unit shall cycle the gas heat on to achieve the unoccupied heating setpoint.
- During the unoccupied cooling mode the supply fan shall be enabled. The economizer dampers shall remain in the full return position, unless outdoor air temperature conditions allow for free cooling. The unit shall cycle the cooling on to achieve the unoccupied cooling setpoint.

Traditional VAV Systems

- Traditional VAV systems feed multiple zones from one unit
- Supply airflow changes to maintain supply duct pressure
- Unit capacity changes to maintain supply air temperature

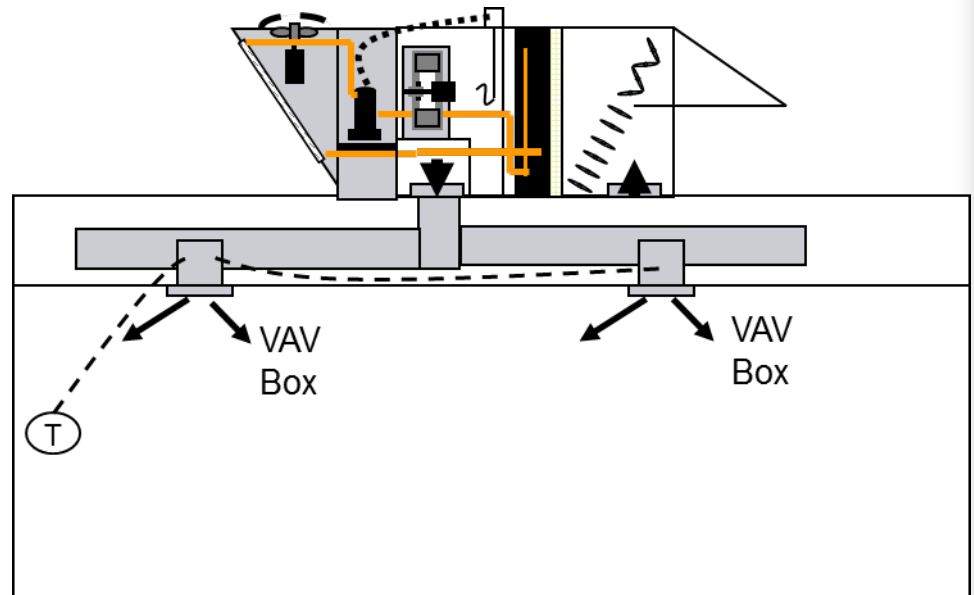

VAV

- Outside air at minimum position 20% adj.
- Cooling on year round during occupied mode
 - Cooling to maintain constant discharge air temperature of 55F adj.
- Compressors to modulate
- First stage of cooling shall be outside air if available through enthalpy/dry bulb economizer
- Fan to modulate to maintain duct static pressure of .75" adj.
- Unoccupied mode to maintain space at 55 heating or 85 cooling adj.

VAV Temperature Reset

- The discharge air temperature setpoint shall be reset based on OA temperature. The setpoint shall adjust on a linear scale.
 - The DAT SP shall be fifty-five degrees Fahrenheit when the outdoor air temperature is at or above seventy-five degrees Fahrenheit.
 - The DAT SP shall be sixty-five degrees Fahrenheit when the outdoor air temperature is at or below forty-five degrees Fahrenheit.

VAV CFM Reset

- The discharge air temperature setpoint shall be reset based on CFM. The setpoint shall adjust on a linear scale.
 - The DAT SP shall be fifty-five degrees Fahrenheit when the CFM is at or above 75% volume.
 - The DAT SP shall be sixty-five degrees Fahrenheit when the CFM is at or below 50% volume.

VAV Morning Warm Up

- Upon a call (BAS or RA Thermostat) for morning warm-up the supply fan shall be enabled to 100%.
- Economizer dampers shall remain in the full return position.
- The heat wheel shall remain off and the bypass dampers open.
- The unit shall cycle the gas heat stages on and off to achieve the return air setpoint.

VAV Morning Cool Down

- Upon a call (BAS or RA Thermostat) for morning cool-down the supply fan shall be enabled to 100%.
- The economizer dampers shall remain in the full return position, unless outdoor air temperature conditions allow for free cooling.
- The heat wheel shall remain off and the bypass dampers open.
- The unit shall cycle the mechanical cooling stages on and off or modulate the economizer dampers to achieve the return air setpoint.

Single Zone VAV Systems

- Single Zone VAV systems serve one zone.
- Airflow changes based on space load
- Unit capacity changes to maintain supply air temperature
- SAT set point can be reset to maintain humidity control (if reheat available)
- VAV boxes not required

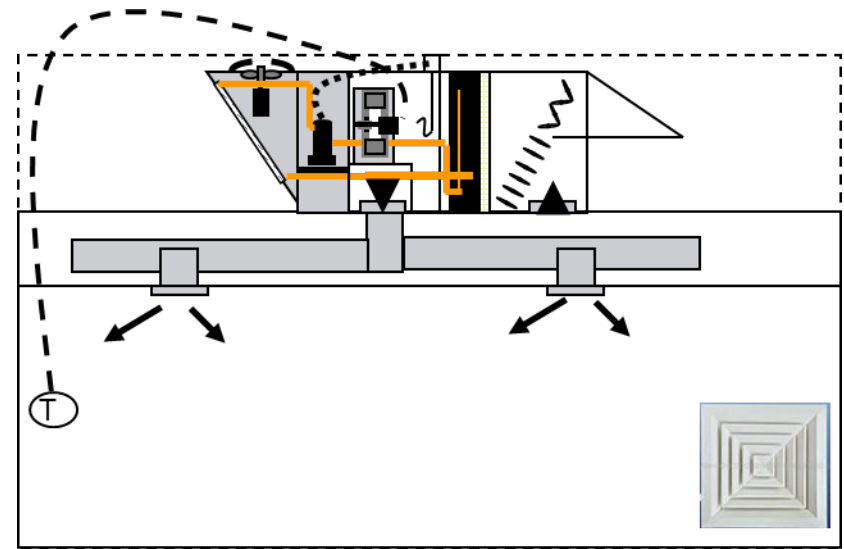

SZVAV

- Heating on with call from space thermostat
 - Stage as required to maintain 70F adj.
- Fan at 100%
- Outside air at minimum position 20% adj.
- Cooling on with call from space thermostat
 - Cooling to maintain constant discharge air temperature of 55F adj.
 - Compressor to modulate
- Fan to modulate to maintain space temperature of 75F adj.
- First stage of cooling shall be outside air if available through enthalpy/dry bulb economizer
- Unoccupied mode to maintain space at 55 heating or 85 cooling adj.

jZone VVT

- Heating on with call from space thermostat (polling or largest offset or designated thermostat)
 - Modulate/stage heat to maintain 85F discharge air adj.
 - 4 stage to 10:1 modulation with gas heat
- Cooling on with call from space thermostat (polling or largest offset or designated thermostat)
 - Cooling to maintain constant discharge air temperature of 55F adj.
 - Compressor to modulate
- Fan to modulate to maintain duct static pressure of .75" adj.
- Outside air at minimum position 20% adj.
- First stage of cooling shall be outside air if available through enthalpy/dry bulb economizer
- No call from space, cooling and heating off, fan to modulate return air to maintain duct static pressure of .75" adj.

DOAS

- Heating on with call from outdoor air thermostat at 65F adj.
- Modulate heat to maintain 70F adj.
- OA & RA dampers at 100%
- Supply and exhaust fan at 100%
- Cooling on with call from outdoor air thermostat at 75F adj. or DP of 50F adj.
- Cooling to maintain constant discharge air dewpoint of 50F adj.
 - Compressor to modulate
 - Hot gas reheat to maintain discharge air at 75F adj.
- Heat wheel shall be on during heating and cooling modes

Heat Wheel

- Wheel shall be on during heating and cooling modes
- Wheel shall be protected from defrost by preheat, VFD or OA bypass
- The heat wheel shall act as first stage heating or cooling.
- The heat wheel shall be locked out when the outdoor air temperature is between fifty-five and seventy-five degrees Fahrenheit.
 - Two bypass dampers, one for outdoor air and one for exhaust air, shall open when the heat wheel is locked out.
 - The exhaust fan shall be enabled when the heat wheel is enabled.

MAU w/o Humidity Control

- Heating on with call from outdoor air thermostat at 65F adj.
 - Modulate heat to maintain 85F adj.
- Outside air at 100%
- Supply fan at 100%
- Cooling on with call from outdoor air thermostat at 75F adj.
- Cooling to maintain constant discharge air temperature of 55F adj.
 - Compressor to modulate
- Room thermostat to reset discharge air temperature as required to maintain space temperature

MAU w/ Humidity Control

- Heating on with call from outdoor air thermostat at 65F adj.
 - Modulate heat to maintain 85F adj.
- Outside air at 100%
- Supply fan at 100%
- Cooling on with call from outdoor air thermostat at 75F adj.
- Cooling to maintain constant dewpoint temperature of 55F adj.
 - Compressor to modulate
 - Room thermostat to activate modulating hot gas reheat to maintain space temperature
 - Room thermostat to reset discharge air temperature as required to maintain space temperature

Process Dehumidification

- At low loads simultaneous heat maybe required to maintain set point
- Return air bypass damper controlled by room thermostat?

Coil Suction Temperature Setpoint Reset

- During dehumidification automatically reset the Coil Suction Temperature Setpoint based on the space or return air humidity sensor condition.

Discharge Air Temperature Setpoint Reset

- During dehumidification automatically reset the Cooling Discharge Air Temperature Setpoint based on the space or return air humidity sensor condition.

Low Limit

- The unit shall be shutdown if the discharge air temperature falls below the low limit set point of 45F adj.
- Low Limit or Freezestat?

Safeties & Timers

- Provide safeties and timers per manufacturers recommendation.

Cartoon

VAV ROOFTOP UNIT

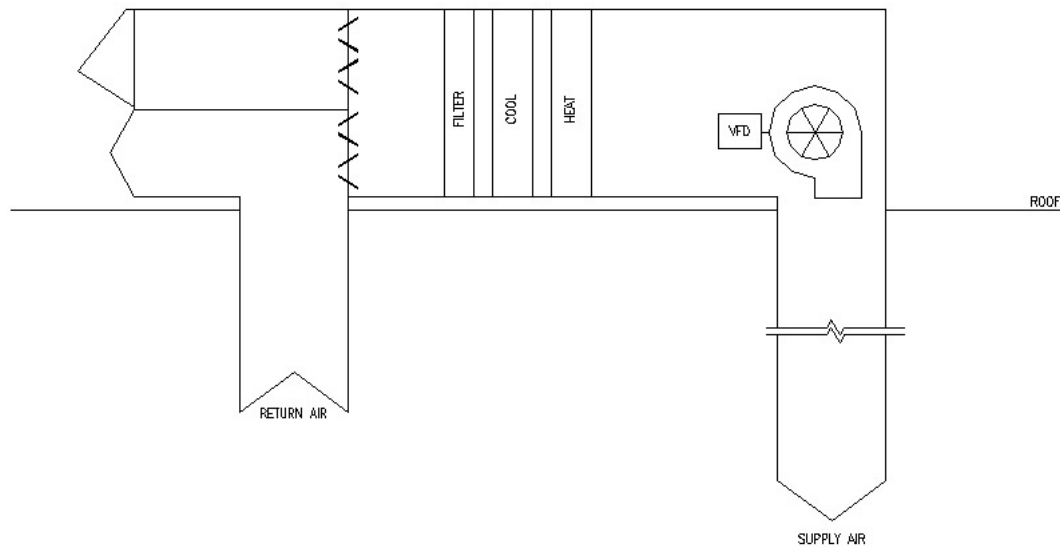

Points List

Unit Type:		VAV Rooftop								
Point Name	Hardware Points				Software Points					Show On Graphics
	BI	AI	BO	AO	AV	BV	Schedule	Trend	Alarm	
Outside Air Temp		X								X
Outside Air Humidity		X								X
Return Air Temp		X								X
Return Air Humidity		X								X
Mixed Air Temperature		X								X
Discharge Air Temperature		X						X	X	X
Duct Static Pressure Sensor		X							X	X
Economizer Dampers				X						X
1st Stage Cooling			X					X		X
2nd Stage Cooling			X					X		X
1st Stage Heating			X							X
2nd Stage Heating			X							X
Supply Fan Status (speed)		X							X	X
Supply Fan Speed				X						X
Supply Fan Start/Stop			X							

Cartoon

VAV ROOFTOP UNIT

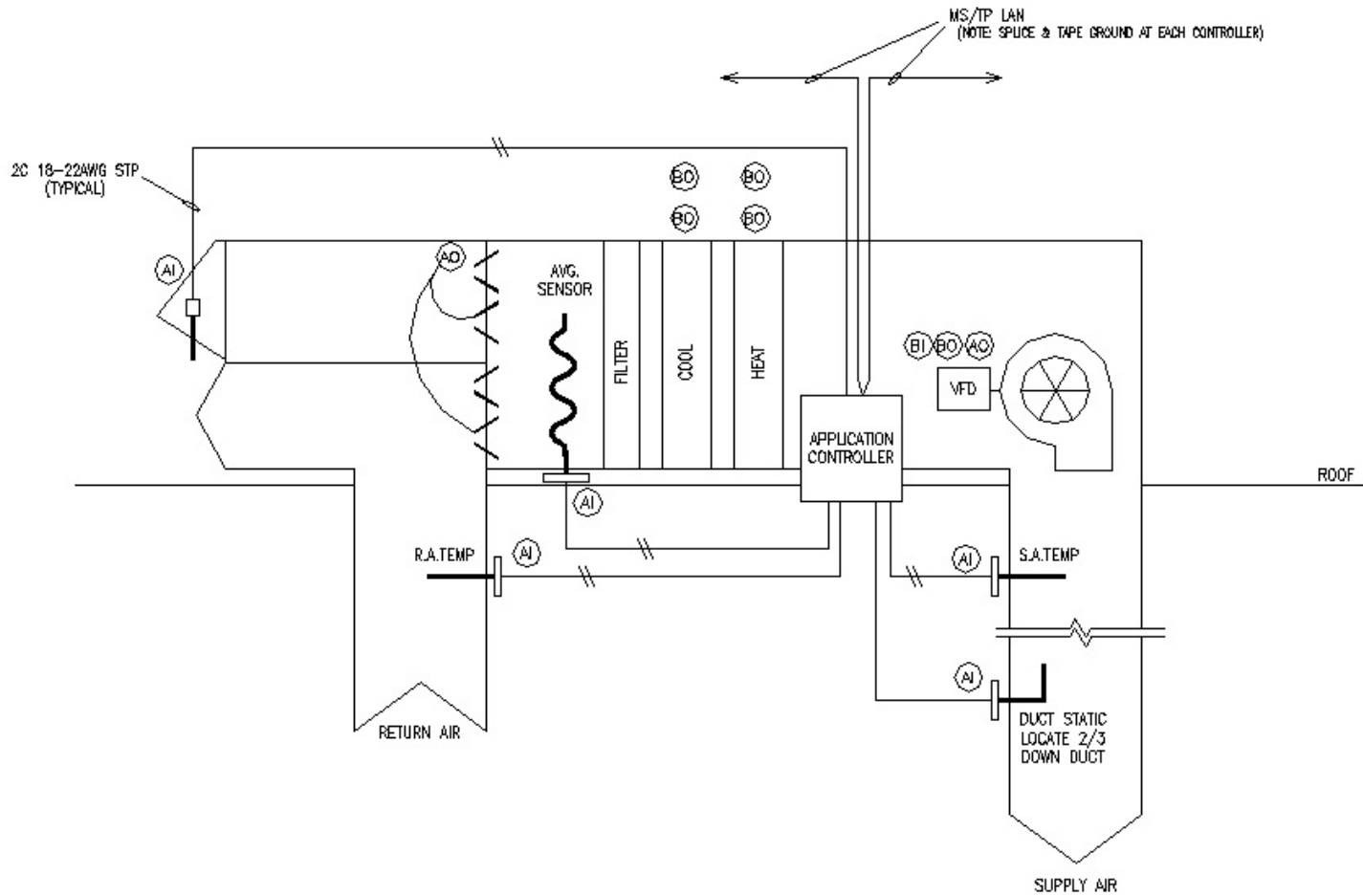

GEO/WSHP

- Start pump or pump run continuously
- Proof of flow
- When loop temperature falls below 60F adj. allow heat injection
- When loop temperature rises above 90F allow heat rejection

Alarming

- The BAS shall generate alarms for the following items:
 - Low limit shutdown
 - Clogged filter alarm
 - Supply fan failure
 - Exhaust fan failure
 - High Temperature in Cooling
 - Low Temperature in Heating

Airflow Measurement

Minimum OA

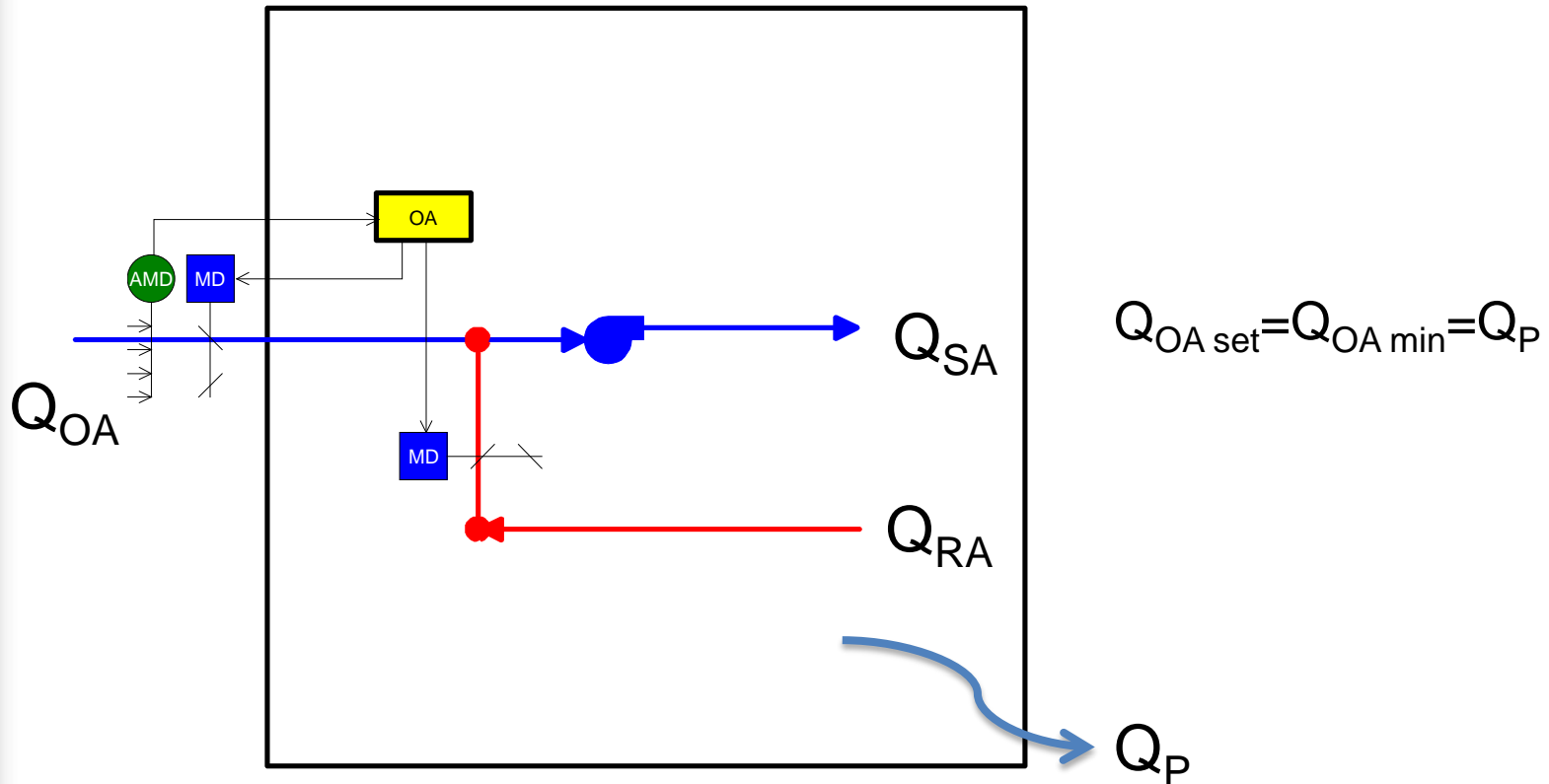

Airflow Measurement

Minimum OA

Modulate OA and RA dampers in sequence to maintain OA setpoint

Or

Modulate OA dampers to maintain OA setpoint

Airflow Measurement

Supply/Exhaust Fan System

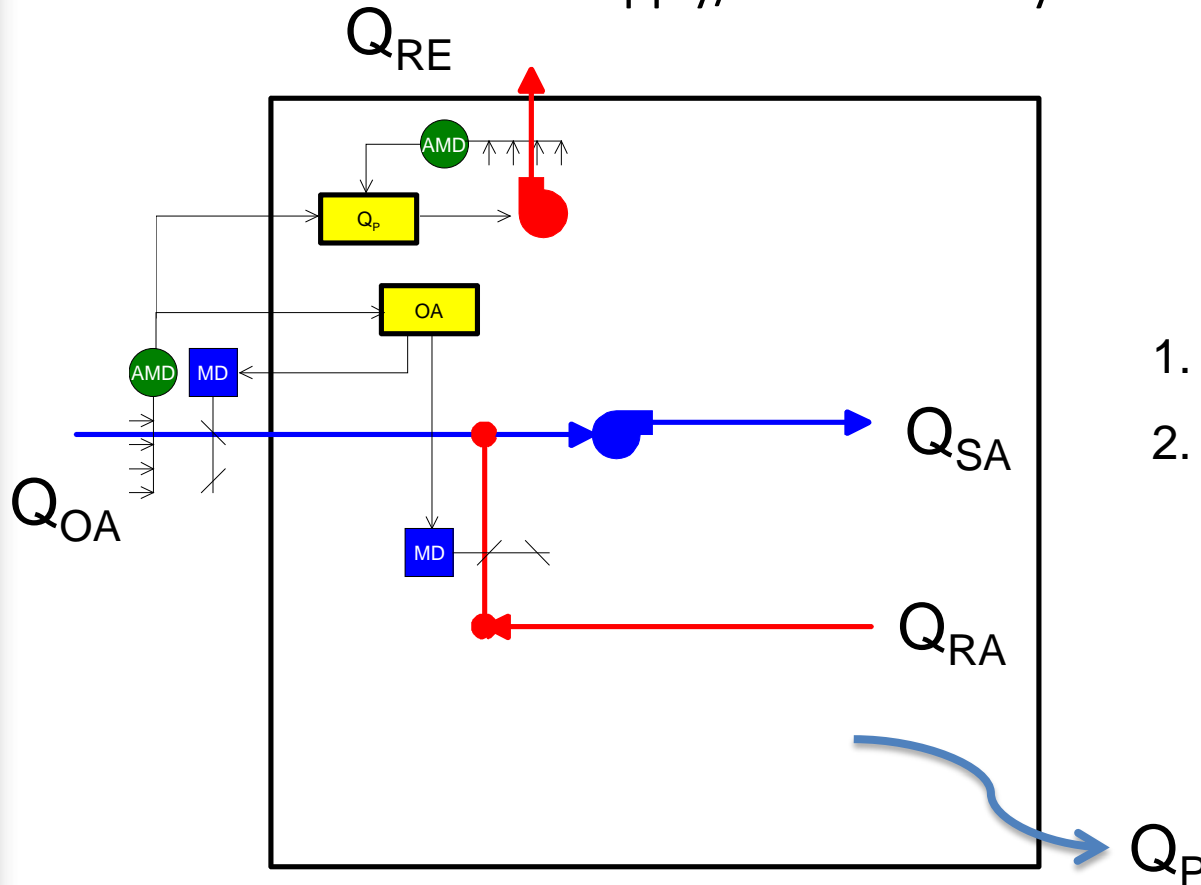

1. $Q_{OA \text{ set}} = Q_{OA \text{ min}}$
2. $Q_{RE \text{ set}} = Q_{OA} - Q_P$

Airflow Measurement

Supply/Exhaust Fan System

Modulate OA and RA dampers in sequence to maintain OA setpoint

Or

Modulate OA dampers to maintain OA setpoint

Modulate relief fan to maintain relief exhaust setpoint

Airflow Measurement

Supply/Return Fan System

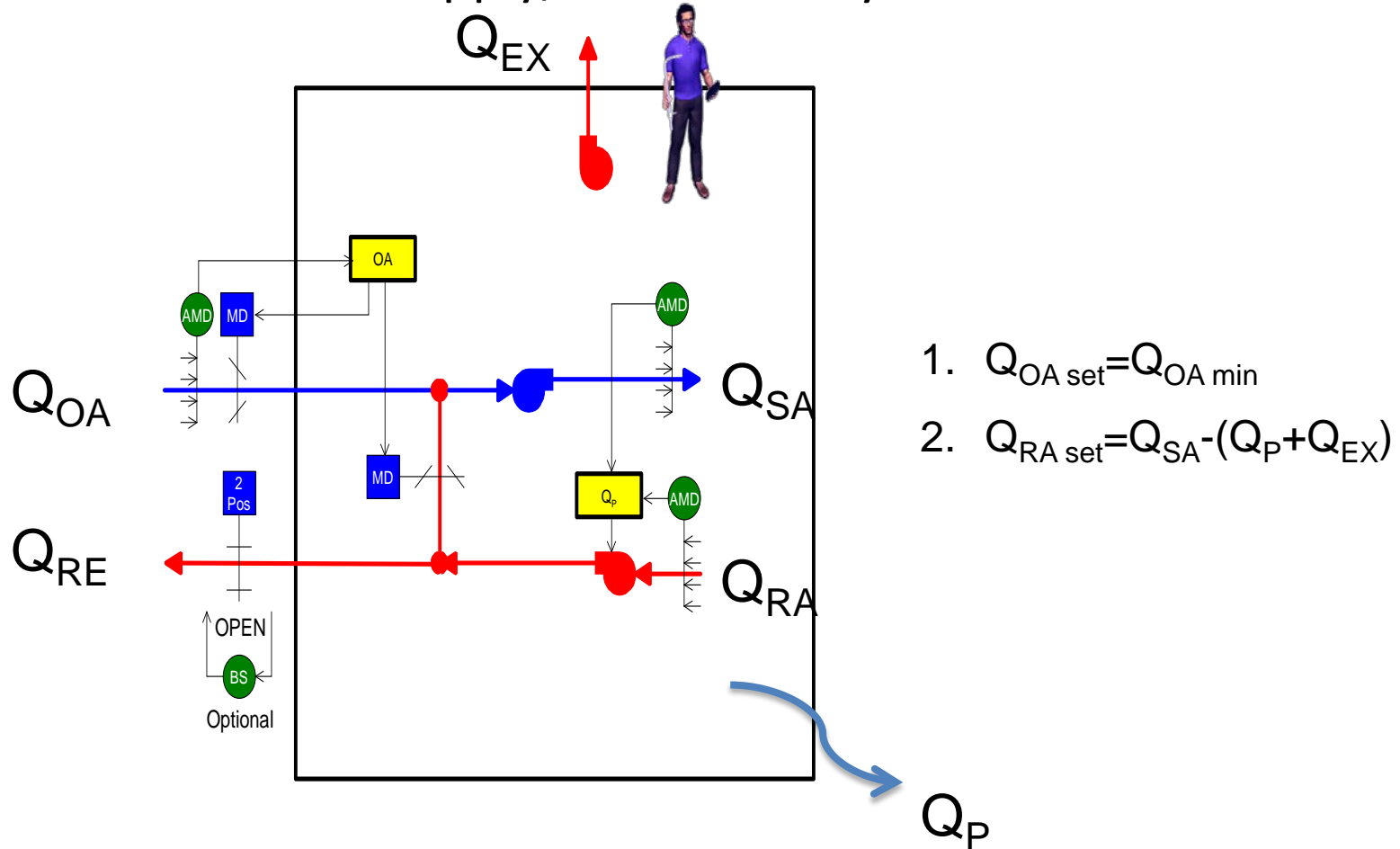

Airflow Measurement

Supply/Return Fan System

Modulate OA and RA dampers in sequence to maintain OA setpoint

Or

Modulate OA dampers to maintain OA setpoint

Use air balance measurement or AFMS to determine exhaust

Modulate return fan to maintain RA setpoint

Airflow Measurement

Minimum OA ERV - Multiple AHU's – Low or High-rise

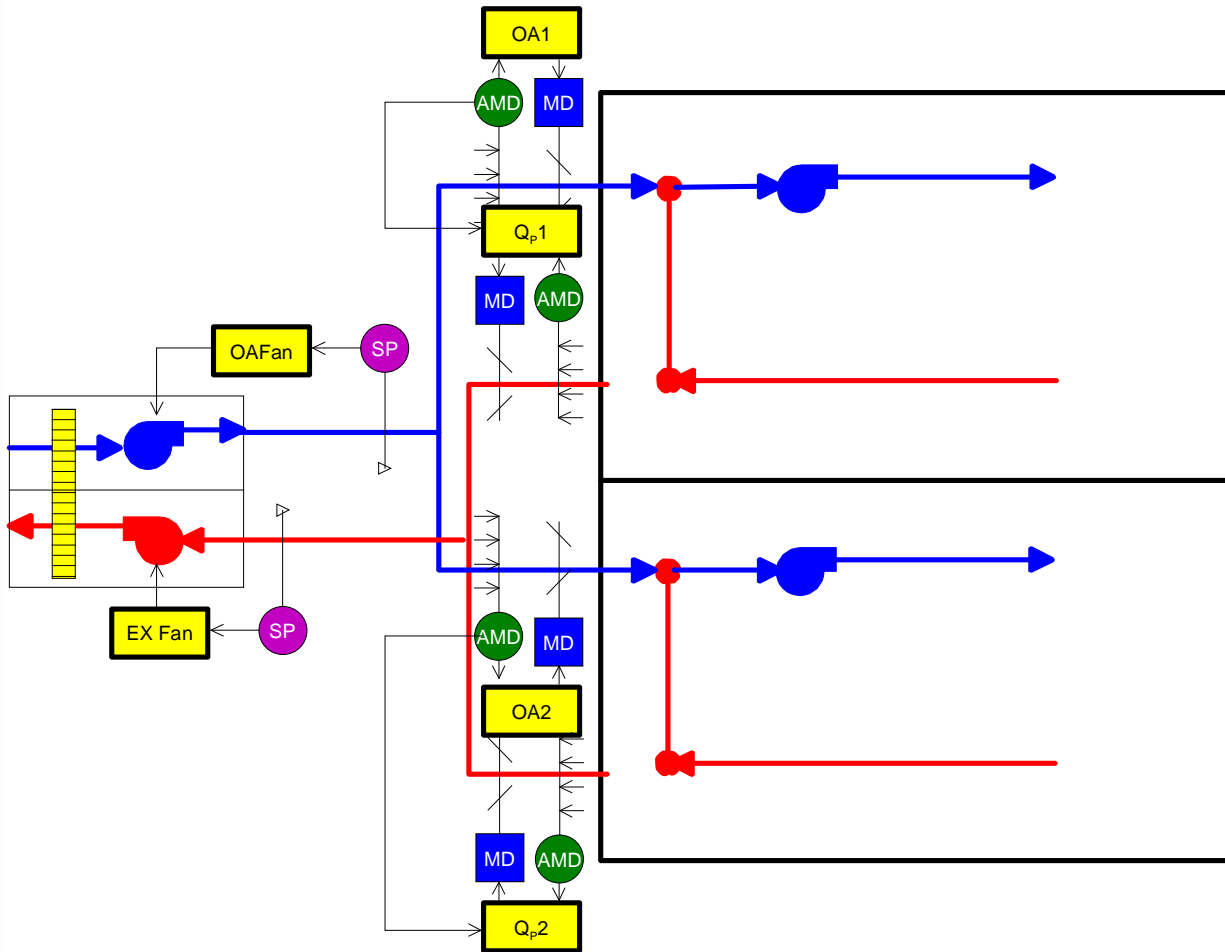

1. $Q_{OA1set} = Q_{OA1min}$
2. $Q_{EA1set} = Q_{OA1} - Q_{P1}$
3. DO FOR ALL ZONES SERVED

Airflow Measurement

Minimum OA ERV - Multiple AHU's – Low or High-rise

1. Modulate ERV SA and EA fans to maintain static pressure setpoint of outdoor air and exhaust air ducts
2. Modulate zone outdoor air damper to maintain OA setpoint
3. Modulate zone exhaust air damper to maintain Exhaust setpoint
4. DO FOR ALL ZONES SERVED

Airflow Measurement

Single Supply/Return/Exhaust - Multiple Floors – High-rise

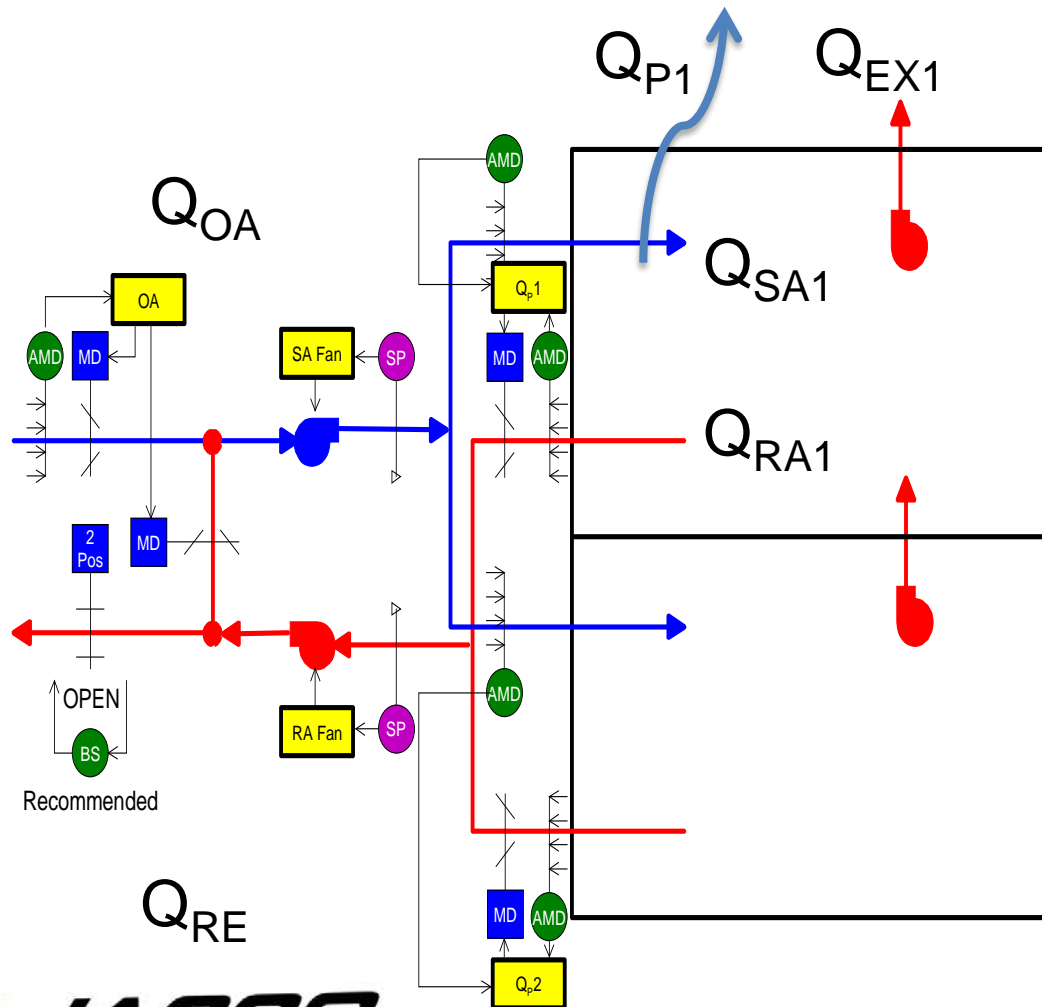

1. $Q_{OA\ set} = Q_{OA\ min}$
2. $Q_{RA1\ set} = Q_{SA1} - (Q_{P1} + Q_{EX1})$
3. DO FOR ALL FLOORS OR PRESSURE ZONES SERVED

Airflow Measurement

Single Supply/Return/Exhaust - Multiple Floors – High-rise

1. Modulate SA and RA fans to maintain duct static (w/reset)
2. Modulate OA and RA dampers in sequence to maintain OA setpoint
3. Modulate floor/zone return damper to maintain RA setpoint
4. DO FOR ALL FLOORS OR PRESSURE ZONES SERVED
5. OPTION: Modulate or open relief damper to maintain slight positive bleed airflow or pressure.

Single Duct VAV Boxes

Single Duct Cooling Only

- With room temperature at setpoint, unit delivers minimum cfm. An increase in room temperature causes airflow to increase. Airflow and temperature setpoints can be different for Occupied, Unoccupied, and Night Setback states.

Cooling with Electric Reheat

- An increase in room temperature over cooling setpoint causes airflow to increase. Below cooling setpoint, airflow is at minimum or zero. A decrease in room temperature below heating setpoint causes airflow to increase to the second heating minimum, as stages of reheat are energized. Airflow and temperature setpoints can be different for Occupied, Unoccupied, and Night Setback states.

Cooling with Proportional Hot Water Reheat

- An increase in room temperature over cooling setpoint causes airflow to increase. Below cooling setpoint, airflow is at minimum or zero. A decrease in room temperature below heating setpoint causes airflow to increase to a fixed heating minimum, or modulate to match water valve action, as hot water valve modulates open. Airflow and temperature setpoints can be different for Occupied, Unoccupied, and Night Setback states.

Series Fan Powered VAV Boxes

Constant Fan VAV Terminal Cooling Only

- Fan operates continuously in Occupied mode, providing constant volume to the space. An increase in room temperature causes cooling airflow to increase. Airflow and temperature setpoints can be different for Occupied, Unoccupied, and Night Setback states for all Constant Fan VAV Terminal sequences.

Constant Fan VAV Terminal with Electric Heat

- Fan operates continuously in Occupied mode, providing constant volume to the space. An increase in room temperature triggers an increase in cooling airflow. Below cooling setpoint, cooling airflow is at minimum or zero. On a decrease in room temperature below heating setpoint, stages of heat are energized.

Constant Fan VAV Terminal with Proportional Water Heat

- Fan operates continuously in Occupied mode, providing constant volume to the space. An increase in room temperature causes cooling airflow to increase. Below cooling setpoint, cooling airflow is at minimum or zero. On a decrease in room temperature below heating setpoint hot water valve modulates open.



Parallel Fan Powered VAV Boxes

Variable Volume Fan VAV Terminal Cooling Only

- At cooling setpoint, unit delivers minimum cooling cfm. An increase in room temperature causes cooling airflow to increase. On a decrease in room temperature below heating setpoint or on a decrease in cooling cfm approaching cooling setpoint (software selectable), unit fan is energized to provide plenum air to the space. Airflow and temperature setpoints can be different for Occupied, Unoccupied, and Night Setback states, for all variable volume fan VAV terminal sequences.

Variable Volume Fan VAV Terminal with Electric Heat

- At cooling setpoint, unit delivers minimum cooling cfm. An increase in room temperature causes cooling airflow to increase. On a decrease in room temperature below heating setpoint or on a decrease in cooling cfm approaching cooling setpoint (software selectable), unit fan is energized to provide plenum air to the space, and stages of heat are energized.

Variable Volume Fan VAV Terminal with Proportional Water Heat

- At cooling setpoint, unit delivers minimum cooling cfm. An increase in room temperature causes cooling airflow to increase. On a decrease in room temperature below heating setpoint or on a decrease in cooling cfm approaching cooling setpoint (software selectable), unit fan is energized to provide plenum air to the space, and hot water valve modulates open.



VRF

- You Don't Have a Choice, BUT...
- Things we like!
 - Alternating Defrost!!!
 - Snow Blow Function
 - Lead/Lag/Alternating Compressor!!!
 - Space or RA Sensor Selection
 - # of Fan Coils per Sensor
- Make Sure Manufacturer Software is Left on the Job!

Samsung Heat Pump VRF System

- Operates entirely in either cooling or heating mode, mixed operation is not allowed

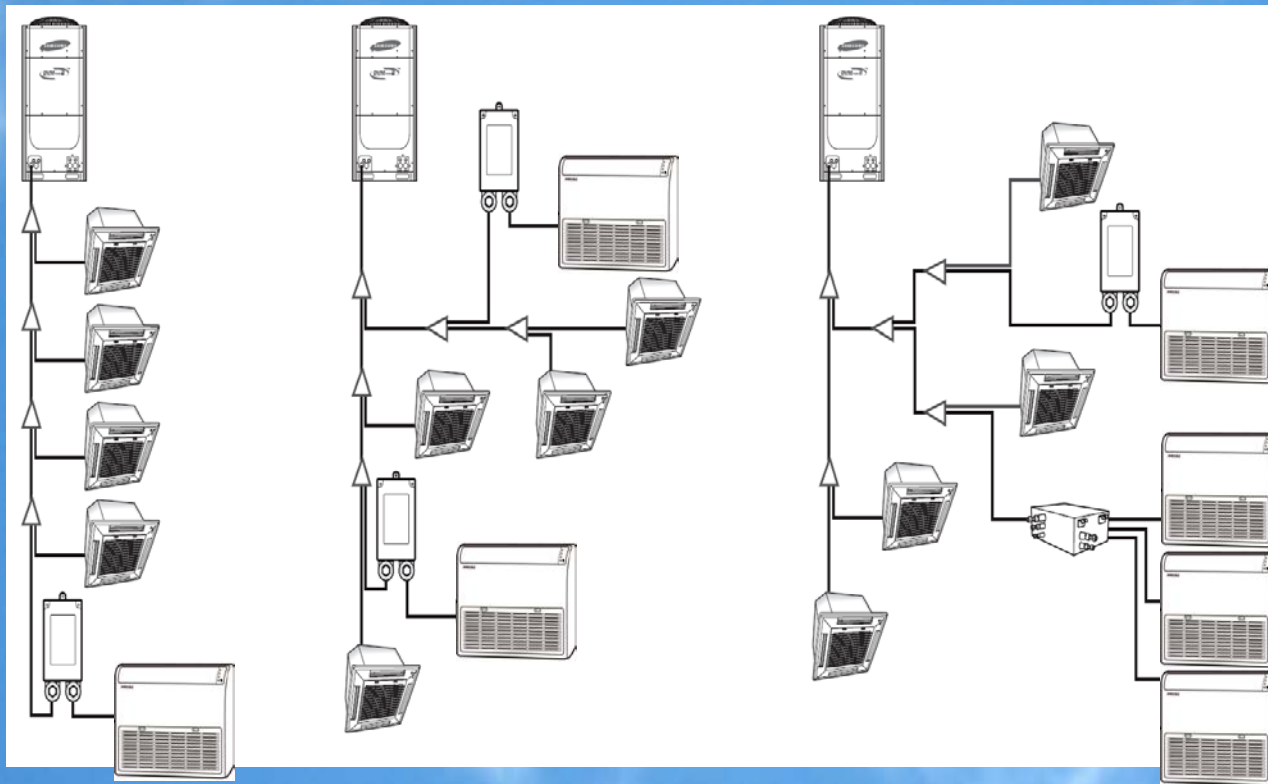

Samsung Heat Recovery VRF System

- Allows simultaneous heating and cooling on a single system. One indoor unit can operate in cool mode while another unit on the same system operates in heat mode.

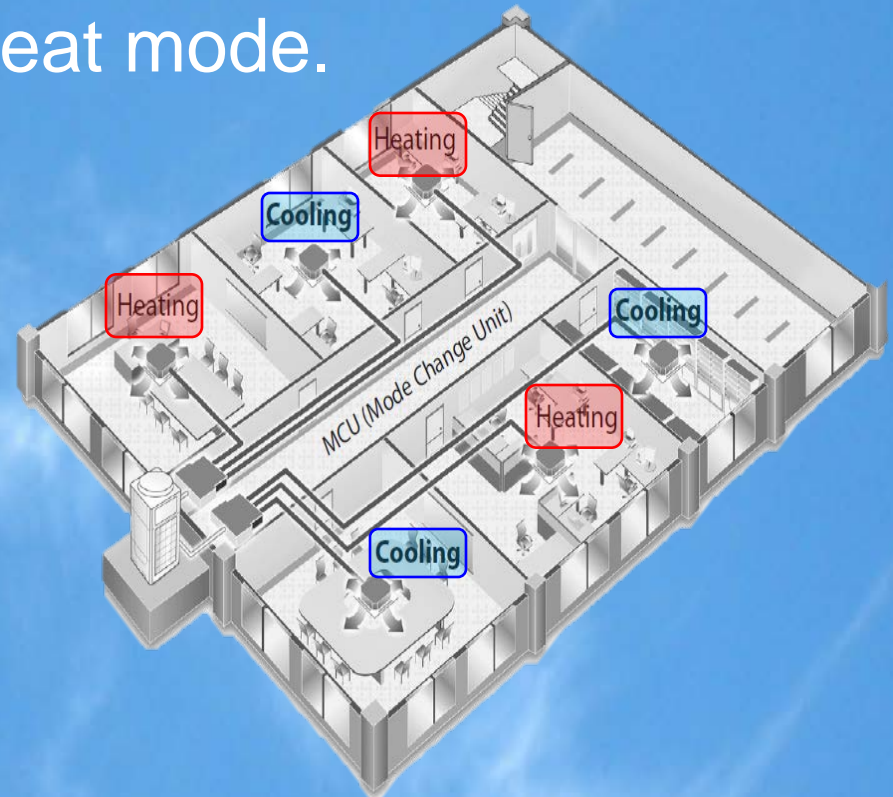
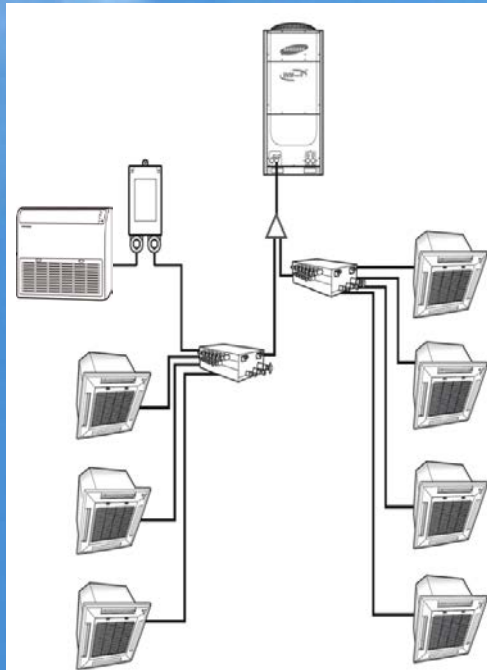

Samsung

Seamless Operation Mode Change

- Samsung DVMS VRF systems have the ability to change operation mode without stopping the compressors

Heating Operation



Cooling Operation

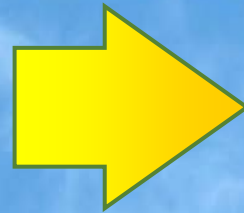

Cooling Operation



Heating Operation

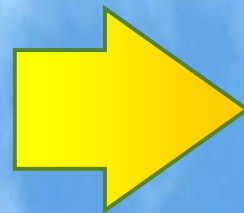

Samsung

Rotational Defrost (HR modular systems only)

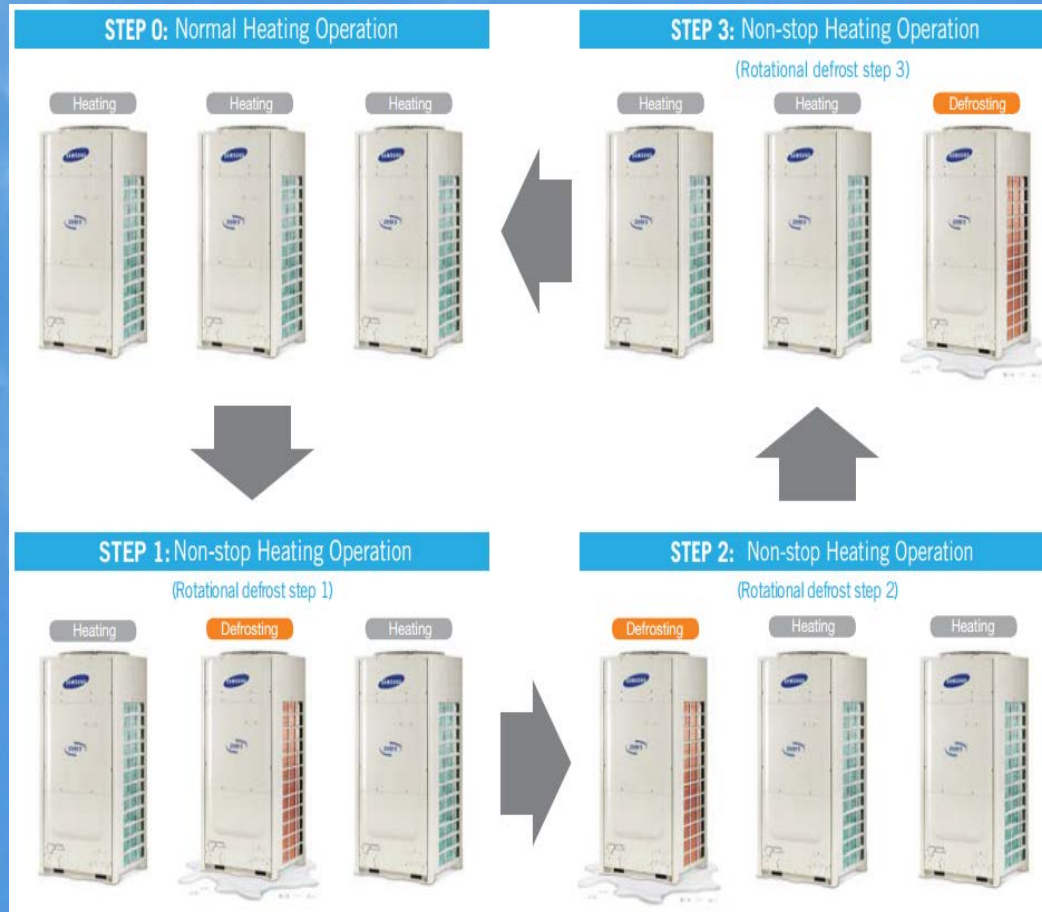

Samsung

Snow Removal Function

- PCB will detect if snow is present
- Removes accumulated snow every 30 min to prevent damage caused by accumulation



Samsung

Smart Inverter Technology

	Case 1	Case 2	Case 3
DVM S (INV+INV)		<p>Alternating operation</p>	
INV+FIX ED or VARI+FI XED			

By Alternating compressor starts, it evens each compressors share of load for enhanced compressor reliability

Samsung DVM S Max Heat

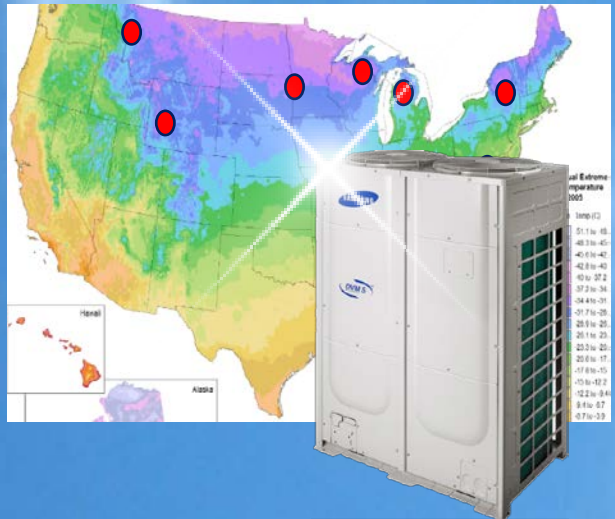

The Extreme Heating Performance

- Provides 100% heating output at -13°F

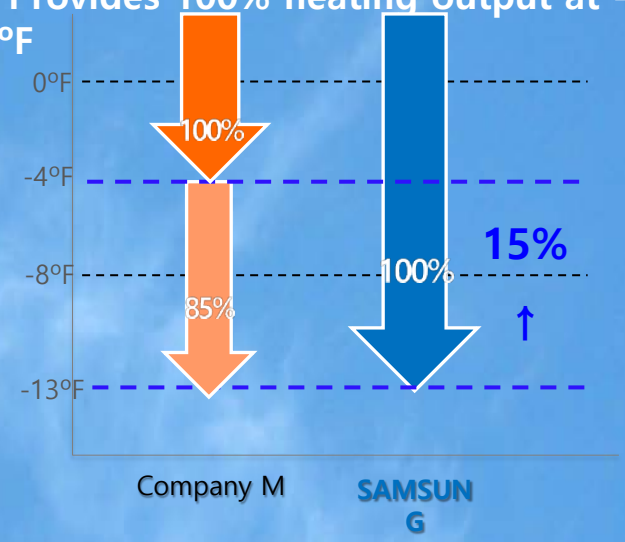

BACnet or MODBUS Adapter

Allows easy and cost effective integration of Samsung HVAC systems to building management systems



Model Number	CL-MC0301C	CL-MC0308C	CL-MC0316C	CL-MC0332C	CL-MC0364C
Maximum indoor unit connection	1	8	16	32	64

Control points
IDU on/off status
IDU operation mode
Set temperature
Room temperature
IDU fan speed control
IDU deco panel louver swing
ODU on/off
ODU mode
Error code

Samsung Data Management

DMS2 allows you to monitor and control your air conditioning system remotely.

It's the easiest and most convenient management control system to manage big air conditioning systems, up to 256 indoor units.

◆ DMS 2.5

- Stand alone web server with 24/7 access
- All management functions integrated



Max. 256 indoor unit
Floor/Area control
Set temperature limit
Operation lock
Cycle data monitoring



Daily/Weekly schedule
Holiday setting
Schedule history

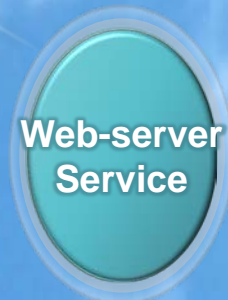

Multiple remote access
Local/Internet control

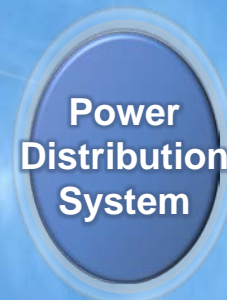

Power distribution to a maximum of 256 indoor units

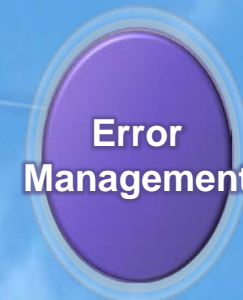

Max. 256 errors
Error storage to memory
Error query
Error notification



Specify multiple conditional inputs that will trigger specified output operations

Thermostat Adapter

- Controls adapter to allow control of RAC, CAC, FJM, and DVM S indoor units via 24 VAC “North American” thermostats
- By allowing third-party thermostats to control SAMSUNG HVAC equipment, you will have the capability to take advantage of popular thermostat features and benefits including, but not limited to, geo-fencing, automatic scheduling, humidity control, weather forecasting and more

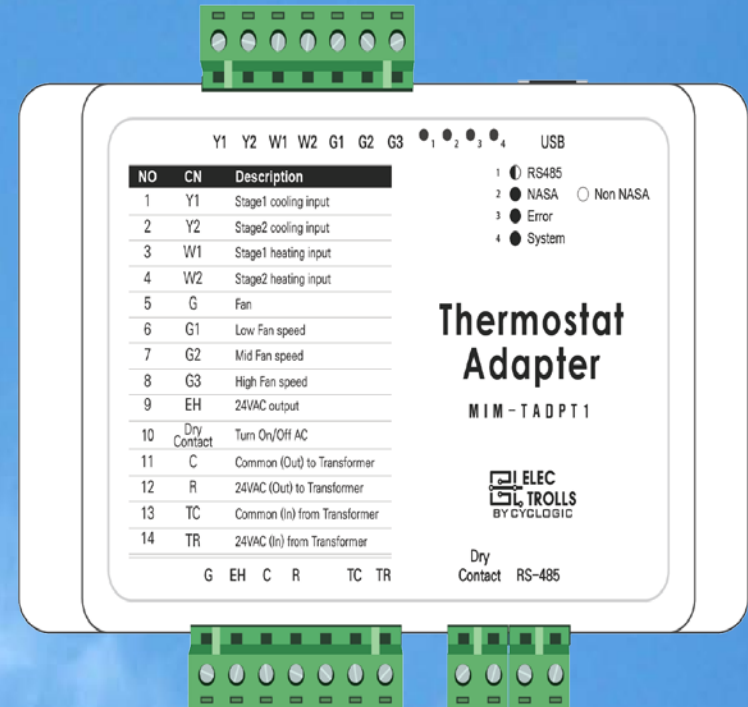

Samsung Modular Chiller

DVM Chiller provides the integrated control system same as the VRF

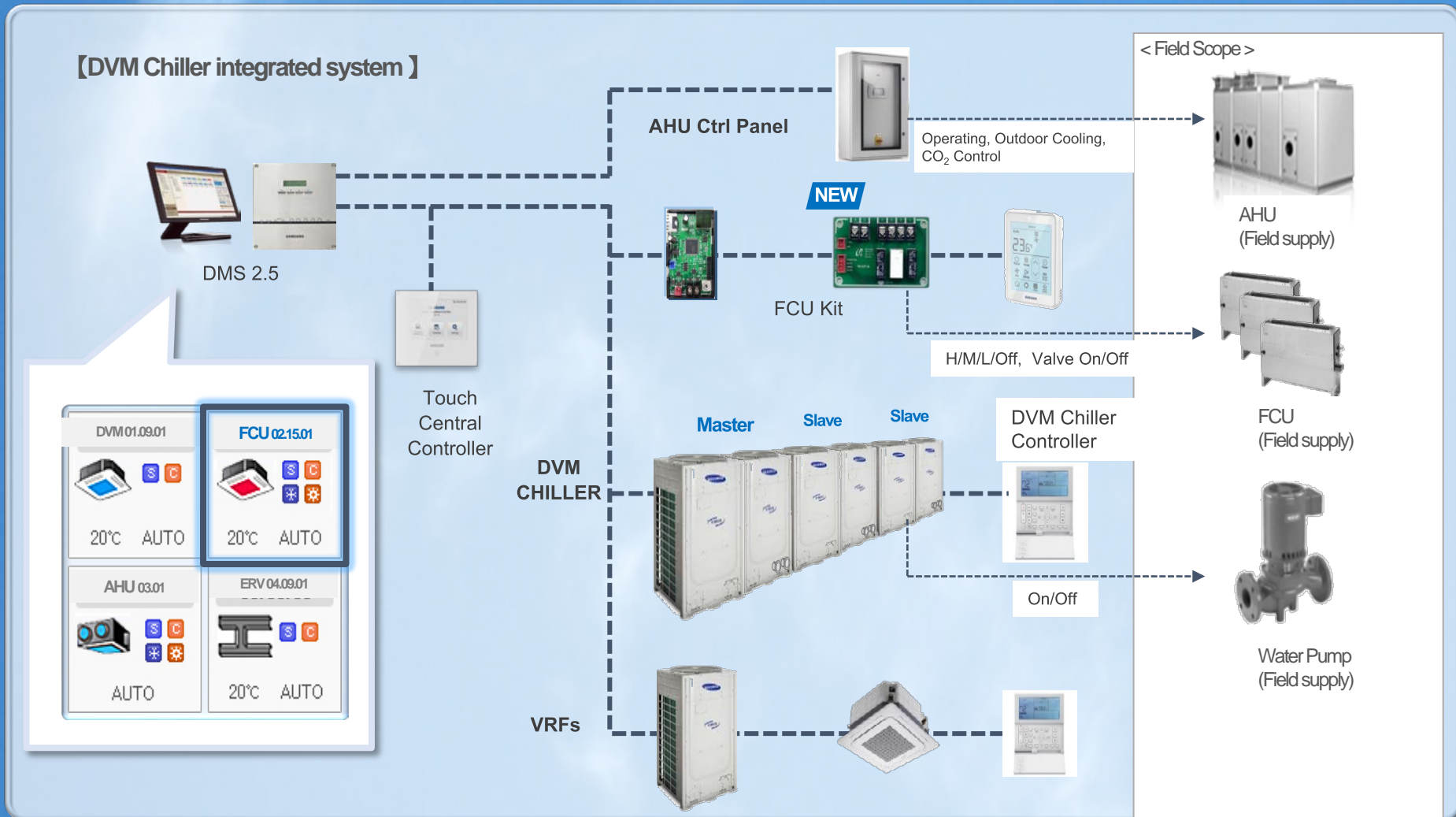

Problem Jobs

Problem

- MAU with heat pump and heat recovery
- Unit set up for SZVAV.
- Building pressure was introduced and the exhaust fan was shut off and the supply fan was running at 100%.

Problem

- 100% OA kitchen make up air unit
- Heat pump with modulating gas heat. The heat pump operates down to 40 degrees and then it switches over to gas heat.
- Modulating gas heat being operated with on - off control. When heat comes on the burner fires off on high fire then modulates down to low fire, waiting for the modulating signal.
- On the cooling side there is one modulating compressor and one on/off compressor. The digital scroll is being treated as an on/off and not modulating.

Problem

- DOAS unit
- TCC added compressor time delays on top of manufacturer compressor time delays.

Problem

- Aeon controls
- TCC added controls to monitor but actually took control of the compressors.

Aaon Unique Sequence of Operations

Digital Scroll Control

- An enable signal is required for compressor 1, then a 1.45vdc signal to start the compressor at min capacity to be modulated up from there.
 - 0 to 1.4vdc = compressor off
 - 1.45vdc to 5.0vdc = 10% - 100% modulation
- Compressor 1 (modulating compressor) needs to be at 90% - 95% capacity for a min of 5 min before compressor 2 (on/off compressor) is turned on. Then compressor 1 should be change to min capacity to then be modulated to maintain desired capacity.
 - When the compressors are controlled by others the control contractor needs to make sure that time delays are programed into the logic to prevent short cycling; Defaults are 3 min Off / 5 min On

Aaon Unique Sequence of Operations

Mod Hot Gas Reheat Control

- The Modulating Hot Gas Reheat Control has to receive an enable signal (Digital Signal)
- Must enable and modulate the digital compressors during dehumidification mode.
- The Suction Pressure Transducer is used to control to a saturated suction temperature during the call for dehumidification, otherwise the sensor is used for monitoring the compressor/coil temperature.
- The control logic needs to set if cooling or dehumidification is priority.
- The Compressors are to maintain a minimum of 75% capacity during dehumidification sequence
- When sending a 0-10vdc signal, this controls the set-point reset that is configured in the controller. This range is adjustable.
 - If the range in the controller is 65 – 80 then 0vdc = 65 and 10vdc = 80.

Aaon Unique Sequence of Operations

ECM/VFD Head Pressure Control

- Discharge Pressure Transducer is used to send a signal to the Condenser Fan VFD/ECM Motor
- No Points/ Inputs needed to control the Condenser Fan ECM/VFD's by the control contactor.

Aaon Unique Sequence of Operations

Mod Gas Control

- Provide an enable signal
- When sending a 0-10vdc signal this controls the set-point reset that is configured in the controller. This range is adjustable. If the range in the controller is 70 – 100 then 0vdc = 70 and 10vdc = 100.

Recommendations

- If controls by TCC...Always provide the sequence to the manufacturer's rep for review and approval.
- If controls by TCC...SLOW DOWN!!!
- Don't mix and match control systems on the same unit.
- Go with factory controls when possible, especially for DX systems, they have invested the time and money to get their sequence to work.

Recommendation

- Move the sequence of operations up in the design process and keep it simple!
- Visit our website, we have posted detailed sequence of operations in the Engineering Tools tab.
- Visit our website, we have this presentation, with simple sequences, posted in the Seminars tab.



Thank You &
Happy Valentine's Day!!!

Jerry Cohen
President
Jacco & Assoc.